

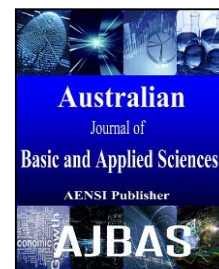

AUSTRALIAN JOURNAL OF BASIC AND APPLIED SCIENCES

ISSN:1991-8178 EISSN: 2309-8414
Journal home page: www.ajbasweb.com



Stability Enhancement of Robust H_{∞} Control: Design and Performance

¹Farzaneh Shahidinoghabi and ²Rajab Asghariyan

¹Department of Electronics, Islamic Azad University of Science and Research Branch, Borujerd, Iran.

²Department of Electronics, Ferdowsi University, Mashhad, Iran.

Address For Correspondence:

Farzaneh Shahidinoghabi, Department of Electronics, Islamic Azad University of Science and Research Branch, Borujerd, Iran.

ARTICLE INFO

Article history:

Received 10 December 2016

Accepted 18 February 2017

Available online 25 February 2017

Keywords:

Stability Enhancement, Robust H_{∞} Control, Design

ABSTRACT

BACKGROUND: Voltage source converter based HVDC using the insulated gate-bipolar transistor (IGBT) and pulse width modulation (PWM) techniques have been utilized in a number of installations which are presently working in many real system. **OBJECTIVE:** In this work, a robust and nonlinear control strategy are investigated in a power system inter connected with a VSC-HVDC system. The controller design is based on the H_{∞} control methodologies to deal with the nonlinearities introduced by requirements to power flow and line voltage. **RESULTS:** First, the steady state mathematical model of the VSC-HVDC system is developed and the relationship between the controlling variables is investigated. By use of H_{∞} control theory, constant DC voltage controller and constant AC voltage controller are designed. A robust H_{∞} control has been proposed to provide voltage support by means of reactive control at both ends; to damp out power oscillations and improve transient stability by controlling either active or reactive power, and to control the power flow through the HVDC link. **CONCLUSION:** The proposed control scheme is tested under several system disturbances like change in frequency at both ends, faults on the converter and inverter buses and change in short circuit ratio. Based upon the time domain simulations in MATLAB/SIMULINK environment, the proposed controller is tested and its better performance is shown compare with the PI controller whose gains are optimized with Genetic Algorithm Technique.

INTRODUCTION

Voltage source converter based HVDC using the insulated gate-bipolar transistor (IGBT) and pulse width modulation (PWM) techniques have been utilized in a number of installations which are presently working in many real system. A VSC-HVDC system connects two AC networks using two AC-DC terminals and a DC link (Guibin Zhang, 2001). VSC-HVDC system has got many advantages over the conventional thyristor-based HVDC system, those are (i) IGBT valve can switch on or off in nano seconds. (ii) no telecommunication channel is required between two VSC-HVDC stations, (iii) The active and reactive power can be Controlled independently. (iv) Active and reactive power of VSC-HVDC transmission systems have made a positive impact on the system dynamics of power systems. The VSC-HVDC transmission link has four control inputs, namely direct and quadrature axis voltages at both the converter stations and their interaction makes system a truly non-linear multi input and multi output control system. The control of all the possibilities is normally achieved through proportional-plus-integral (PI) controllers. These PI controllers suffer from the inadequacies of providing suitable control and transient stability enhancement over a wide range of system operating conditions under various faulted situation. Several authors have presented mathematical models and control strategies for VSC-HVDC transmission that include small signal stability (G.Asplund, 2000), decoupling control in converter stations using feedback linearization (Guibin Zhang, 2001), LMI based robust control (G.B.Zhang, 2002), and

Open Access Journal

Published BY AENSI Publication

© 2017 AENSI Publisher All rights reserved

This work is licensed under the Creative Commons Attribution International License (CC BY). <http://creativecommons.org/licenses/by/4.0/>



Open Access

ToCite This Article: Farzaneh Shahidinoghabi and Rajab Asghariyan., Stability Enhancement of Robust H_{∞} Control: Design and Performance. *Aust. J. Basic & Appl. Sci.*, 11(2): 167-172, 2017

adaptive control (M. Durrant, 2004, S.Y. Ruan, 2007 and Haifeng Liang, 2005). Most of these papers have considered a point to point VSC-HVDC system without considering a parallel AC line in which case the sending and receiving ends are completely decoupled. Although some research has been conducted for coupled VSCHVDC systems (Si-Ye Ruan, 2007, B.C. Pal, 2002, Sylvain Lignon, 2006 and P.K. Dash, 2009), to explore the possibility of their smooth operation, till a lot of aspects are yet to be investigated thoroughly. However also these previous studies were at the expense of neglecting a number of very important features in HVDC system operation, particularly related to the HVDC-HVAC interactions. In this study, a robust nonlinear H_∞ controller is applied to the HVDC Light transmission systems in order to improve the dynamic behavior performance under wide range of operating and faulted conditions. The controller design is based on a state feedback H_∞ controller. This paper clearly describes the advantages of H_∞ controller the effectiveness of the robust controllers is demonstrated using the simulation studies with the aid of the MATLAB software package. The simulation results show that the controllers contribute significantly to improve the dynamic conditions, enhance the system stability and damp the undesired oscillations. The rest of the paper is organized in six sections as follows. In section 2, the time domain mathematical model is presented. In section 3, Genetic Algorithm based PI controller and the H_∞ feedback controller and the H_∞ controller a feedback case for VSCHVDC system is presented. Simulation results are presented that illustrates the effectiveness of the proposed strategies in section 4. At last, conclusions are drawn in Section 5.

Mathematical Modeling of VSC-HVDC System:

A typical VSC-HVDC transmission link consists of two converter stations. One station operates as the rectifier station where as the other operates as the inverter station. A parallel AC line is connected between the two terminals to show the coupling action. The dynamics of the rectifier and the inverter can be described as follows:

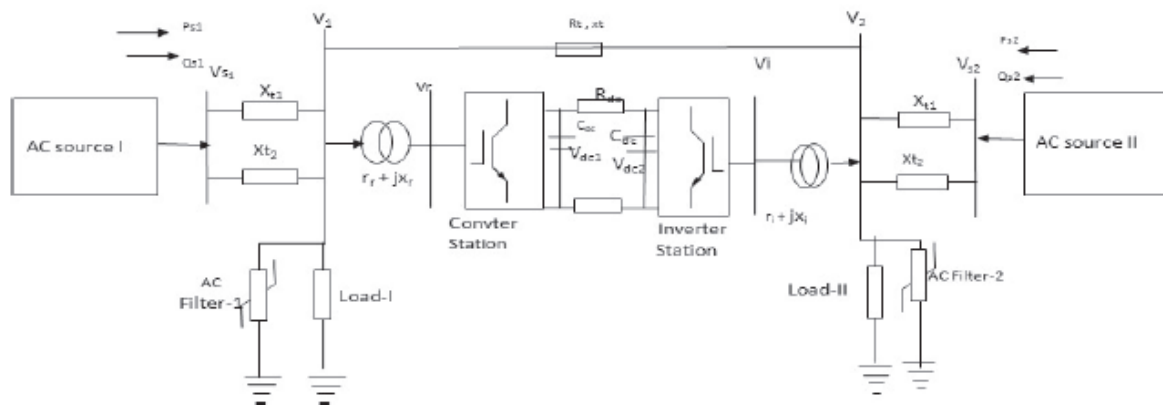

Fig.1: VSC-HVDC Model

2.1. Rectifier Model:

The dynamic equations of rectifier station are given as following.

$$\frac{dI_{rD}}{dt} = \frac{-r_r}{l_r} I_{rD} + \omega_1 I_{rQ} + \frac{V_{1D}}{l_r} - \frac{V_{rD}}{l_r} \quad (1)$$

$$\frac{dI_{rQ}}{dt} = \frac{-r_r}{l_r} I_{rQ} - \omega_1 I_{rD} + \frac{V_{1Q}}{l_r} - \frac{V_{rQ}}{l_r} \quad (2)$$

$$\frac{dV_{dc1}}{dt} = \frac{P_{dc1}}{C_{dc} V_{dc1}} - \frac{I_{dc}}{C_{dc}} \quad (3)$$

Where I_{rD} , I_{rQ} and V_{rD} , V_{rQ} are the d-q axis currents and voltages of the rectifier station. V_{1D} , V_{1Q} are the d-q axis ac voltages of rectifier station. V_{dc} is the dc voltage after the rectifier station. C_{dc} and V_{dc} are the current and capacitor of the dc link. The corresponding impedances on the rectifier side is $r_r + jx_r$. P_{dc} is the power flow in the DC link.

nterval model:

The dynamic equations of inverter station are given as following.

$$\frac{dI_{iD}}{dt} = \frac{-r_i}{l_i} I_{iD} + \omega_2 I_{iQ} - \frac{V_{2D}}{l_i} + \frac{V_{iD}}{l_i} \quad (4)$$

$$\frac{dI_{iQ}}{dt} = \frac{-r_i}{l_i} I_{iQ} - \omega_2 I_{iD} - \frac{V_{2Q}}{l_i} + \frac{V_{iQ}}{l_i} \quad (5)$$

Where I_{iD}, I_{iQ} and V_{iD}, V_{iQ} are the d-q axis currents and voltages on the inverter sides, V_{2D}, V_{2Q} are the corresponding ac voltages on inverter stations. $R_i + jX_i$ is the impedance of the inverter station. The dc link voltage is V_{dc} and I_{dc} is ac current in inverter station

Control Scheme for VSC-HVDC System:

Normally PI controller is used for this purpose for providing damping to the system oscillations. In conventional PI controller direct axis and quadrature axis voltages V_{rd} and V_{rQ} are the control inputs of the rectifier and V_{id} & V_{iQ} control input of the inverter. Choosing the right value for K_p and K_i of a PI controller is really a difficult task and also the optimum value change with the changing system operating conditions. Thus the gains of PI controller are optimized for improving damping performance significantly. Further H- infinite controller has been proposed that gives better stability to the system under abnormal conditions. This controller also provides large operating zone within which the system can operate without loss of generality.

The PI controller is designed to provide coupled and independent control of the DC link voltage and the generator side reactive power for converter station and the control of active power and reactive power for inverter station. The state variables of rectifier station are taken as I_{rd}, I_{rQ} and V_{dc} . For convenience dc voltage and reactive power of the rectifier are taken as the output variables. Since the reference bus d-axis voltage is taken as zero, the reactive power directly controlled by I_{rQ} . The state variables of inverter station are I_{id}, I_{iQ} . Since the inverter station is operating in the active and reactive control mode the output states are taken as I_{id}, I_{iQ} . Here the trial and error technique is avoided and Genetic Algorithm is used to optimize the values of the gains $K_{p1}, K_{r1}, K_{p2}, K_{r2}, K_{p3}, K_{r3}$ and K_{p4} . Both of the result has been demonstrated by simulation. Since the equations are in the nonlinear form those can be linearized by perturbation and the small signal model given for VSC-HVDC.

$$A_R = \begin{bmatrix} -\frac{r_r}{l_r} & \omega_{10} & 0 \\ -\omega_{10} & -\frac{r_r}{l_r} & 0 \\ \frac{-u_{10}}{v_{dd} \cdot C_{dc}} & \frac{v_1 - u_{20}}{v_{dd} \cdot C_{dc}} & \frac{(-u_{10})i_{rD} + (v_1 - u_{20})i_{rQ}}{v_{dd}^2 \cdot C_{dc}} - \left(\frac{1}{r_{dc} \cdot C_{dc}} \right) \end{bmatrix}$$

$$A_i = \begin{bmatrix} -\frac{r_i}{l_i} & \omega_{20} \\ -\omega_{20} & -\frac{r_i}{l_i} \end{bmatrix}, \quad B_r = \begin{bmatrix} 1 & 0 & 0 \\ 0 & 1 & 0 \\ 0 & 0 & 1 \end{bmatrix}, \quad B_i = \begin{bmatrix} 1 & 0 \\ 0 & 1 \end{bmatrix}$$

$$E_r = \begin{bmatrix} \frac{1}{l_r} & 0 \\ 0 & \frac{1}{l_r} \end{bmatrix}, \quad E_i = \begin{bmatrix} \frac{1}{l_i} & 0 \\ 0 & \frac{1}{l_i} \end{bmatrix}, \quad C_r = \begin{bmatrix} 1 & 0 & 0 \\ 0 & 0 & 1 \end{bmatrix}, \quad C_i = \begin{bmatrix} 1 & 0 \\ 0 & 1 \end{bmatrix}, \quad D_r = \begin{bmatrix} 0 & 0 & 0 \\ 0 & 0 & 0 \end{bmatrix},$$

$$D_i = \begin{bmatrix} 0 & 0 \\ 0 & 0 \end{bmatrix}$$

Simulation Result:

To test the robustness of the designed controller for the HVDC Light transmission link, the operating condition of the system are $P_r = 0.8$ pu, $Q_r = 0.2$ pu, $P_i = 0.6$ pu and $Q_i = 0.2$ pu. From the following figures it is evident that the oscillations in the speeds of the generators and the interarea oscillations are damped out faster with the new controller than the conventional PI controller. Due to H_∞ control for the reactive power control loop at the rectifier station, the voltage of the converter ac-bus recovers much faster. Further, the fault at the converter bus affects the power flow to the inverter bus due to presence of a parallel AC line. The DC-bus voltages are stabilized very well using this controller.

The system is simulated with a LLLG fault at bus-1 from 1 sec to 1.2 second. Due to the fault the ac voltage at the corresponding bus is decreased to a critical level. The performance of the proposed controller is much better than the conventional PI controller and optimized PI controller. The performance improvement with the H_∞ controller are shown in Fig.2.(i-viii), which clearly indicates the robustness of the proposed controller. The damping property marginally improves along with the reduction in overshoot and settling time. Less overshoot is important as it avoids the saturation of the converter currents.

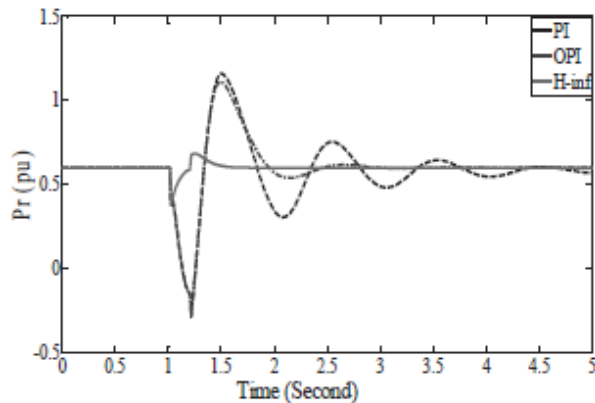

Fig.2.(i)variation of active power of rectifier station.

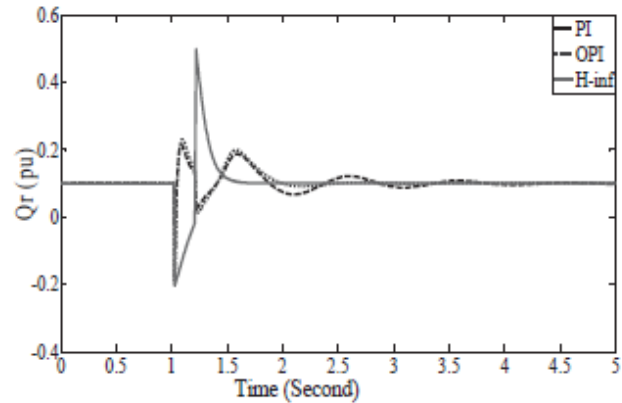

Fig.2.(ii)variation of reactive power of rectifier station

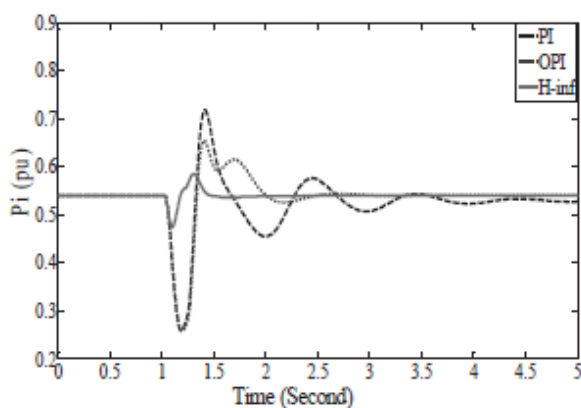

Fig.2.(iii)variation of active power of inverter station

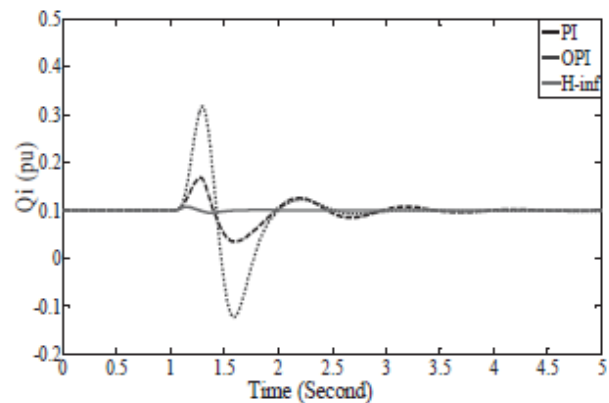

Fig.2.(iv)variation of reactive power of inverter station

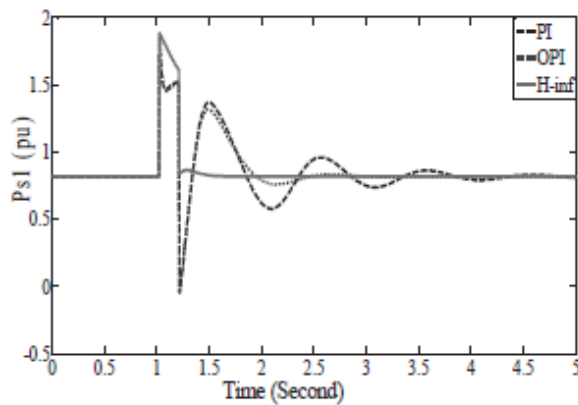

Fig.2.(v) variation of power at generator bus

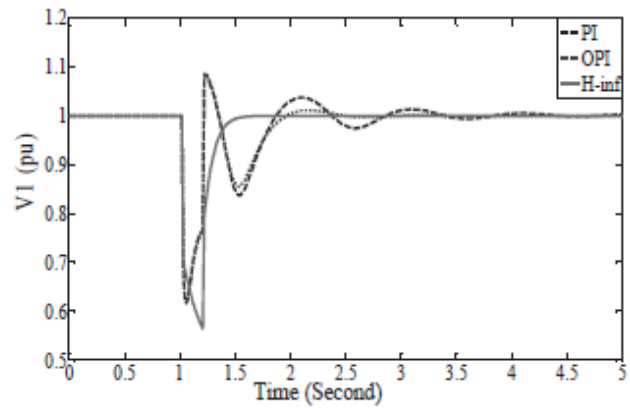
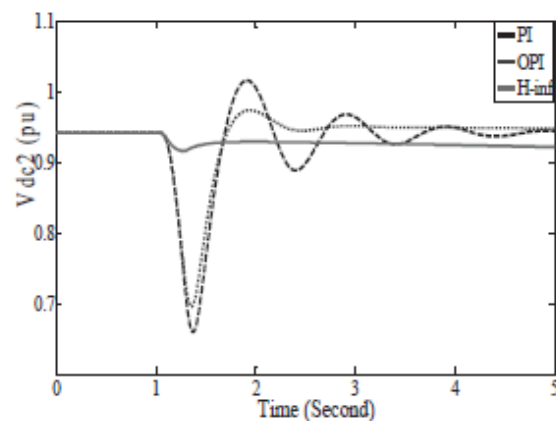
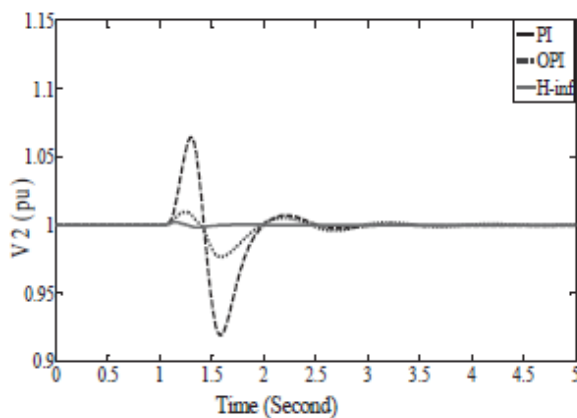

Fig.2.(vi) variation of AC voltage of rectifier station



Conclusion:

In this paper a state feedback H-inf. controller has been applied to VSC-HVDC system. The proposed controller is found to be robust producing significant damping and reduction of overshoots for a variety of operating conditions that include LLG fault at the converter buses, Low short circuit ratio for ac side of the inverter station and change in angular frequency etc. In comparison with the conventional PI controller and GA based optimized PI controller, the proposed controller performs superior. The results showed that the performance of the proposed controller is much better than the conventional PI controller and optimized PI controller. The performance improvement with the H ∞ controller indicates the robustness of the proposed controller. The damping property marginally improves along with the reduction in overshoot and settling time. Less overshoot is important as it avoids the saturation of the converter currents.

REFERENCES

- Al Jowder, F.A.R., B.T.Ooi, 2004. "HVDC LIGHT Station with SSSC Characteristics", IEEE Tran. on Power Electronics, 19: 1053-1059.
- Andersen, B.R., P.J.Lexus, P.Horton, Cartwright, 2002. "Topologies for VSC transmission", Power Engineering Journal, 16: 142-150.
- Asplund, G., 2000. "Application of HVDC Light to power system enhancement", IEEE Power Engineering Society Winter Meeting, 4: 2498-2503.
- Dash, P.K. and A.K. Moharana, 2009. H ∞ controller for stability enhancement in VSC HVDC system with parallel AC lines, 1: 215-242.
- Durrant, M., H. Werner and K. Abbott, 2004. "Synthesis of multi-objective controllers for a VSC HVDC terminal using LMIs", IEEE Conference on Decision and Control., pp: 4473-4478.
- Guibin Zhang, Zheng Xu, 2001. "Steady-state model for VSC based HVDC system and its controller design", IEEE Power Engineering Society Winter Meeting, 3: 1085-1090.
- Guibin Zhang, Zheng Xu, 2001. "Steady-state model for VSC based HVDC system and its controller design", IEEE Power Engineering Society Winter Meeting, 3: 1085-1090.

Haifeng Liang, Gengyin Li, Guangkai Li, Peng Li and Ming Yin, 2005. "Analysis and Design of H_{∞} controller in VSC HVDC system" IEEE/PES Transmission and Distribution conference & Exhibition: Asia and Pacific, China, pp: 1-6.

Pal, B.C., 2002. "Robust damping of interarea oscillations with unified power flow controller" , IEE Proc. Gen. Trans. Distrib., 149(6): 733-738.

Ruan, S.Y., G.J.Li,X.H.Jiao,Y.Z.Sun,T.T.Lie, 2007. " Adaptive control design for VSC-HVDC system based on back stepping approach", Electric Power System Research, 77(5-6): 559-565.

Si-Ye Ruan, Guo-Jie Li, Li Peng, Yuan-Zhang Sunand T.T.Lie, 2007. "A nonlinear control for enhancing HVDC light transmission system stability". Electrical power and energy systems, 29: 565-570.

Sylvain Lignon, Jean-Jacques Sinou, Louis Jezequel, 2006. "Stability analysis and mu-synthesis control of brake systems" Journal of Sound and Vibration, 298(4-5): 1073-1087.

Zhang, G.B., Zexel, G.Z.Wang, 2002. " Steady state model and its nonlinear control of VSC-HVDC system, Proc. CSEE, 22: 17-22.

Zhang, G.B., Zexel, G.Z.Wang, 2002. " Steady state model and its nonlinear control of VSC-HVDC system, Proc. CSEE, 22: 17-22.