

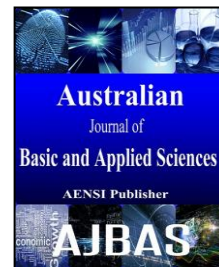

ISSN:1991-8178

## Australian Journal of Basic and Applied Sciences

Journal home page: www.ajbasweb.com



### Design and Development of Fuzzy Logic Based Controller for Effective Utilization of Wind Energy Conservation System

<sup>1</sup>N.M. Godwin Dhas and <sup>2</sup>M. Mary Linda

<sup>1</sup>Assistant professor, Department of Electrical and Electronics Engineering, Ponjesly college of engineering, Nagercoil-3, India

<sup>2</sup>Professor, Department of Electrical and Electronics Engineering, Ponjesly college of engineering, Nagercoil-3, India.

#### ARTICLE INFO

##### Article history:

Received 3 June 2015

Received in revised form 17 June 2015

Accepted 1 August 2015

Available online 15 October 2015

##### Keywords:

Pulse Width Modulation Control circuit, Wind Machines, Fuzzy Logic Controller, Buck Boost converter.

#### ABSTRACT

In Domestic Wind Machines, if the wind speed is low, the output voltage is not sufficient to charge the battery as it is lower than the rated charging voltage of the battery. This limits the overall efficiency of the Wind Machine to 20%. This paper proposed to design and develop a **Fuzzy Logic Controller (FLC)** for the effective utilization of the wind machine. By implementing a FLC based Buck Boost converter, the voltage produced at the lower wind speeds can also be utilized effectively by boosting it to the rated charging voltage of the battery. Also if the wind speed is high (>14 m/s), the DC output voltage will increase to more than 65 V. The converter bucks this high voltage to the nominal battery charging voltage (52 V), thereby protecting the battery from over charging voltage. Thus effective utilization of the wind machine has been achieved by the use of the proposed Buck Boost Controller.

© 2015 AENSI Publisher All rights reserved.

**To Cite This Article:** N.M. Godwin Dhas and M. Mary Linda., Design and Development of Fuzzy Logic Based Controller for Effective Utilization of Wind Energy Conservation System. *Aust. J. Basic & Appl. Sci.*, 9(27): 704-707, 2015

#### INTRODUCTION

The demand for energy has increased tremendously in the past few decades. As a result, the use of renewable energy sources like solar energy, wind energy etc., is gaining popularity. Thus the Domestic Wind Machines (<10 kW) are extensively used in both rural and urban areas to generate electric power from wind energy. In Domestic Wind Machines, if the wind speed is low, the output voltage from the Wind Machine after rectified into DC is less. The battery will not charge as it is lower than the rated charging voltage. This happens most of the time in a day, since the wind speed in domestic regions is in the range of 0 to 4 m/s. This limits the efficiency of a conventional domestic Wind Machine to 20 %. Therefore, an efficient control mechanism is needed, so as to utilize the wind power effectively.

In this paper we have proposed a Fuzzy Logic Controller (FLC) based Buck- Boost converter, so that the voltage produced at the lower wind speeds can also be utilized effectively by boosting it to the rated charging voltage of the battery. The FLC constantly monitors the output voltage from the Wind Machine. Corresponding to the magnitude of the DC output from the rectifier, the controller calculates and changes the width of the pulse given to the converter,

to boost it to the rated voltage of the battery. Thus the battery is charged even when the wind machine rotates at lower speed (0-4 M/S). If the wind speed is high (>14 m/s), the DC output voltage is also high. The converter bucks this high voltage to the battery charging voltage thereby protecting the battery from over voltage.

#### II. Specification of the Wind Machine System:

##### 2.1. Wind Machine:

##### 2.2 Wind Turbines:

A wind turbine is characterized by its power-speed characteristics. For a horizontal axis wind turbine, the amount of power  $P_t$  that a turbine is capable of producing is given by

$$P_t = \frac{1}{2} * C_p * \rho * A * V^3 \quad (1)$$

where  $\rho$  is the air density, A is the swept area of the turbine and v is the wind velocity. The  $C_p$  parameter is called the power coefficient and is dependent on the ratio between the linear velocity of the blade tip ( $R * W_t$ ) and the wind velocity (V). This ratio, known as the tip-speed ratio, is defined as where R is the radius of the turbine. This kind of application is designable with constant or variable speed.

$$\lambda = \frac{\omega_t * R}{V} \quad (2)$$

**Corresponding Author:** N.M. Godwin Dhas, Assistant professor, Department of Electrical and Electronics Engineering, Ponjesly college of engineering, Nagercoil-3, India.  
E-mail: nmgodwin@gmail.com

Different types of wind turbines are available on the market. The different types of wind turbines have their own advantages and disadvantages. Fixed-speed wind turbines normally cause a voltage drop during start-up (Manwell, J.F., 2002). The voltage drop is mainly caused by reactive power consumption during magnetization of the generator. Another problem concerned to wind turbines with fixed speed is the flicker produced during normal operation of the wind turbine. Once this method the energy extraction is optimized for

one point of operating, it means that for only wind speed is achieved the maximum value of extraction.

The variations in the generated power are mainly caused by the wind turbines and the tower shadow effect. These variations can lead to flicker emission. Variable-speed wind turbines can reduce these power variations and eliminate the flicker caused by power pulsation, becoming possible to maximize the energy extraction using an appropriated control method.



Fig. 1: Wind Machine.

3. Fuzzy Logic Controller:

Fuzzy logic is applied to wind farm control with the goal of pass-through the complex, non-linearity and uncertainty of these control systems. In (Reznik Leonid, 1997) are present some limitations of conventional controllers as: nonlinear models are computationally intensive and have complex

stability problems. A plant does not have accurate models due to uncertainty and lack of perfect knowledge, uncertainty in measurements and multivariable's and multiloops systems have complex constraints and dependencies.

3.1. Fuzzy Logic control:

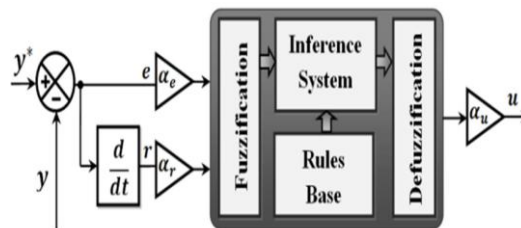

Fig. 2: Fuzzy controller structure.

The Fuzzy Inference System (FIS) evaluates at each time which control rules are appropriate using the base knowledge. The defuzzification unit computes the crisp output of the rules leading to the optimal plant control. The typical TSFC configuration is given in Fig.5

$$e(nP_s) = \mu^*(nP_s) - \mu(nP_s)$$

$$r(nP_s) = e(nP_s) - e(nP_s - P_s) \tag{3}$$

Where n: Positive integer,  $P_s$  : Sampling time,  $y^*$  : Set point,  $e(nP)$ : Error,  $r(n)$ : Error rate,  $y(nP)$  system output.

In this work, the FLC design uses the hand-tuning method considering, in the first stage, the classical PI as a reference. The conventional PI is replaced by a Fuzzy PI with a discrete approximation depicted in (2). The same response

of the closed loop system verifies of the right implementation.

$$\mu_n = K_p \cdot (e_n + \frac{1}{P_t} \sum_{j=1}^n P_s) \tag{4}$$

The defuzzification process computes output with assigning a representative value to the fuzzy variable. The output of the TS model is calculated by the weighted average given in (3)

$$\mu^* = \frac{\sum_{i=1}^m \mu(z_i) \cdot Z_i}{\sum_{i=1}^m \mu(Z_i)} \tag{5}$$

3.2. Membership Functions:

The highest excursion of the inputs is scaled to the input universe in order to avoid saturation. The signals sizing are obtained with adjusting the FLC gains. To increase sensitivity, the input

universe is split into seven triangular sets crossing their adjoining at the medium membership value as depicted.. This provides a sufficient sensitivity in the case study. The output sets are reduced to singleton to simplify the Center of Gravity (COG) defuzzification algorithm.

**IV. Control Circuit:**

The program for the ATmega8L controller is done using IDE and the hex code for burning it in the chip is generated. This hex code is virtually

burnt in the Microcontroller The input and output voltages of the Buck Boost converter are given to the ADC pins of the Microcontroller. Port D of the Microcontroller is connected to the LCD. The LCD displays the digital values of the input and output voltages. The program burnt in the Microcontroller is such that it adjusts the duty cycle of the PWM signal depending upon the values of the ADC. The PWM output is available in the OC1A pin of the controller and can be visualized through the Virtual Oscilloscope.

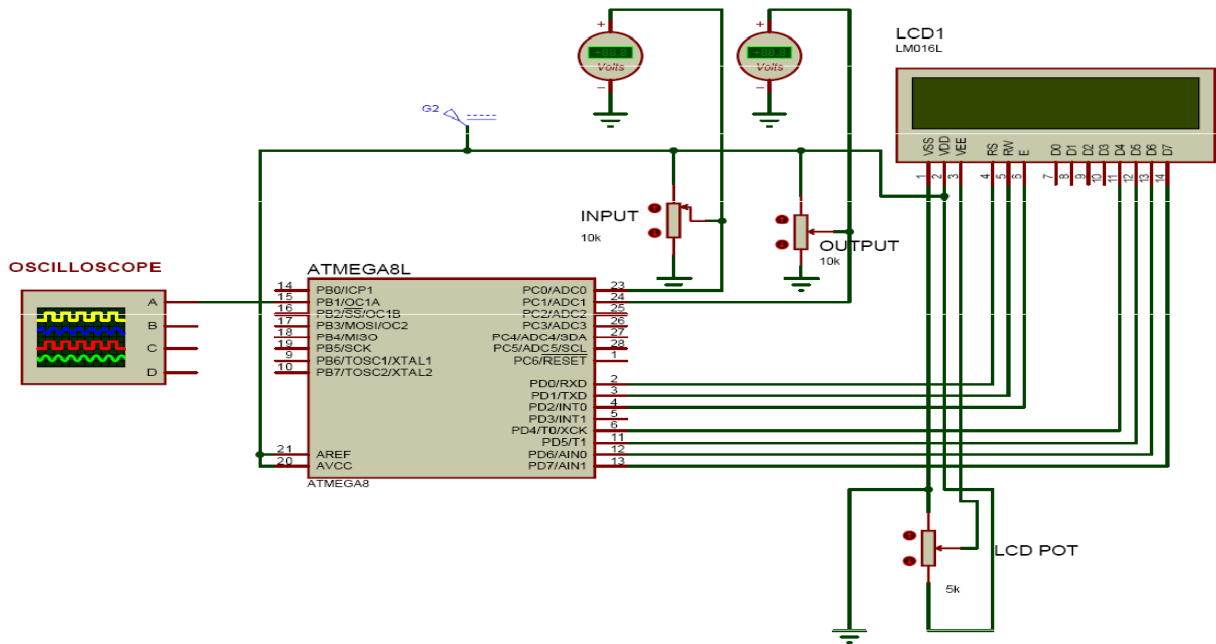

**Fig. 3:** Control Circuit Simulation using ISIS Proteus 7.5

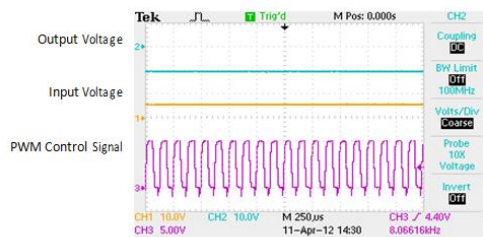

**Fig. 4:** Waveforms Captured for 5 V Input.

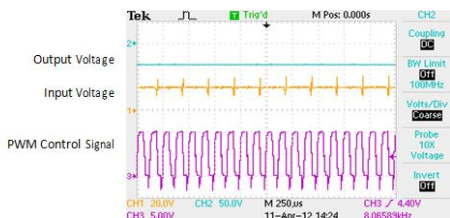

**Fig. 5:** Waveforms Captured 20 V Input.

The testing of the kit for various ranges of input voltages shows the correctness of design of the Buck Boost controller. Thus by using this controller the voltage obtained at lower wind speeds can be boosted and used to charge the battery effectively

and hence the efficiency of this system is comparatively higher than the existing system.

**Conclusion:**

The proposed system of Fuzzy logic controller

based Buck Boost converter is found to be more compact, user friendly and more efficient. Its performance could be maximized and optimized considering only the control of wind turbine Speed. So, this control method is not based in analytical or empirical expressions but in real effects allowing having a control method independent from systems characteristics. The use of fuzzy logic allows at solving the problems of non-linear and high complexity of the power coefficient behavior.

## REFERENCES

Ahmet Duran Sahin, 2004. "Progress and recent trends in wind energy" , Progress in energy and combustion science, 30: 501-543.

Das, D., S.K. Aditya and D.P. Kothari, 1999. "Dynamics of diesel and wind turbine generators on an isolated power system" , Electrical power and energy systems, 21: 183-189.

Wang, L., 1994. "Adaptive Fuzzy System and Control", Prentice- Hall, New Jersey.

Galadi, V., A. Piccolo and Siano, 2008. "Designing an Adaptive Fuzzy Controller for Maximum Wind Energy Extraction", IEEE Trans. On Energy Conversion, 23: 559-569.

Wang, Q., L. Chang, 2004. "An Intelligent Maximum Power Extraction Algorithm for Inverter Based Variable Speed Wind Turbine Systems". IEEE Transactions on Power Electronics, 19(5): 1242-1249.

Manwell, J.F., J.G. Mcgowan, A.L. Rogers, 2002. Wind Energy Explained – Theory, Design and Application. Wiley: England, 8: 369-425.

Ross Timothy J., 1995. Fuzzy logic With Engineering Applications. McGraw Hill, 1995; 1:1-15, 2:17-35.

Reznik Leonid. Fuzzy Controllers. Newnes, Oxford, 1: 1-9.

Mitchell, D.M., 1988. DC-DC Switching Regulator Analysis, New York: McGraw-Hill.

Mohan, N., T. Undeland and W. Robbins, 1995. Power Electronics: Converters, Applications, and Design, 2nd ed., New York: John Wiley & Sons.