

## A New Approach Based on Fuzzy Controller for Volt/Var Control in Distribution System

M. Nayeripour, H. Khorsand, A. R. Roosta and T. Niknam

Shiraz University of Technology, Shiraz, Iran

---

**Abstract:** In this paper we concern about implementing nonlinear Fuzzy controller which regulates the modulation index of voltage source converter (VSC), which is used in an uninterrupted power supply (UPS) application, to control Volt/Var in the grid. The UPS controls the voltage at the point of common coupling (PCC). A LC filter is linked at the output of the VSC to eliminate switching harmonics. In the fuzzy controller the value of modulation index of VSC, is determined from a fuzzy rule-base defined on PCC voltage error ( $e = V_0 - V_{ref}$ ) of the point of common coupling. The proposed fuzzy controller is designed using simple control rule-base and the most natural membership functions. The comparative performances of the proposed fuzzy controller and the conventional PI controller, have been investigated through wide range of operating condition such as harmonics, unbalancing and voltage sag/swell. From the simulation studies it has been found out that the performance of the proposed fuzzy controller is better than that obtained by the conventional PI controller.

**Key word:** UPS, Fuzzy controller, PCC, operating condition

---

### INTRODUCTION

Voltage unbalance in three phase power grids occurs because of the appearance of different load levels in each phase of the grid. Since the differences of load levels, various current was drawn from the source and passing in the RL filters connected to the VSI (Fig. 1), and cause different voltage drops in the filter of each phase, and an unbalanced filters output voltage ( $v_{ABC}$ ) was happened. The VSI topology to supply three and single phase AC loads, require a neutral connection to feed each phase voltage independently, as shown in Fig. 1. Voltage unbalance can interrupt or even damage some three-phase loads. For instance, under unbalanced voltage, three-phase current of the induction machine can be highly distorted and current in one phase can be higher than the nominal value. In addition, over-voltages will damage the insulation of a stator winding. These can shorten the motor's life. Thus, international standards prohibit too high voltage unbalances. So regulation sinusoidal voltages have gained substantial attention over the last few years. In addition, the concern for global warming has seen considerable evolvement in the distributed generation (DG) technology in the recent time. An uninterruptible power supply (UPS) can give solution for the power quality problem such as harmonics, unbalancing, voltage sag/swell, while supplying clean power from DGs simultaneously. Generally UPSs are used to provide low distortion, battery back up to computers, regulated sinusoidal voltages to critical loads such as data-processing, communication, and medical electronics systems. UPSs can be off-line type in which they remain unemployed until power outage occurs and start supplying power subsequently. The on-line type UPS continuously powers the protected load from its reserve while synchronously resupplying the reserve by drawing power from the utility supply. In this paper, the application of the UPS has been extended. It is assumed that the UPS is fed by a distributed generator. The DG can be a PV stack or fuel cell stack or battery which supplies the dc bus of the voltage source converter (VSC) connecting the UPS to the ac network, and assumed that the UPS is connected at the point of common coupling (PCC) of the utility and a major load center. A PWM inverter is used to supply the load, a LC low-pass filter must be used to eliminate the switching frequency component of output voltage harmonics. The cut off frequency of this filter is set 500Hz and the switching frequency of this PWM inverter is set 1kHz. The model of this PWM inverter with L-C filter is shown in Fig3.

---

**Corresponding Author:** M. Nayeripour, Shiraz University of Technology, Shiraz, Iran

Wen Zhang (2008) presents a new formulation of multi-objective reactive power and voltage control for power System basis of the fuzzy sets theory and particle swarm optimization (PSO). Andrija T. Saric (2003) proposed The solution technique for the described discrete-type combinatorial optimization problem is fuzzy dynamic programming, with the optimization criterion containing the maximization of their minimum contentment degree and maximization of the sum of these minimums. Abdelouahab Bouafia (2009) proposes direct power control by selecting the efficient state of the converter three-phase PWM rectifiers using a new switching plan, without line voltage sensors. In (Al-Kandari, A.M., 2006) a method based on fuzzy linear assessment for voltage flicker measurements is presented. The suggested algorithm uses the digitized samples of the voltage signal at the situation where the power quality standards are executed. Akbar Rahideh (2006) propose a new method based on fuzzy logic for voltage/reactive power control and concurrently loss reduction in power systems. The purpose is to provide a solution, which does both voltage improvement and loss reduction for every feasible power systems. N. Yadaiah (2004) proposes a fuzzy controller based coordinated controller to impede an electric power system losing synchronism after a large sudden fault and to achieve good post-fault voltage level. Ilhan Kocaarslan (2005) presents an implementation of a fuzzy gain scheduled proportional and integral (FGPI) controller for load-frequency control of a two-area electrical interconnected power system. K.H.Abdul Rahman (1995) presents an artificial intelligence approach to the optimal reactive power control problem. H. Camblong (2007) presents a new controller for a four-leg Voltage Source Inverter (VSI) which enable generating a balanced voltage under unbalanced load conditions. Xu Yan (2005) presents an innovative voltage and reactive power control system based on fuzzy logic and dynamic borderline implementing fuzzy control theory. He reduce the adapt times of transformer tap and capacitor effectively and improve the control function. But, in non of the above, fuzzy controller as a controller for controlling modulation index in voltage source converter (VSC) was not take into consideration. In this paper we concern about implementing Fuzzy controller for controlling modulation index in voltage source converter (VSC), which is used in an uninterrupted power supply (UPS) application.

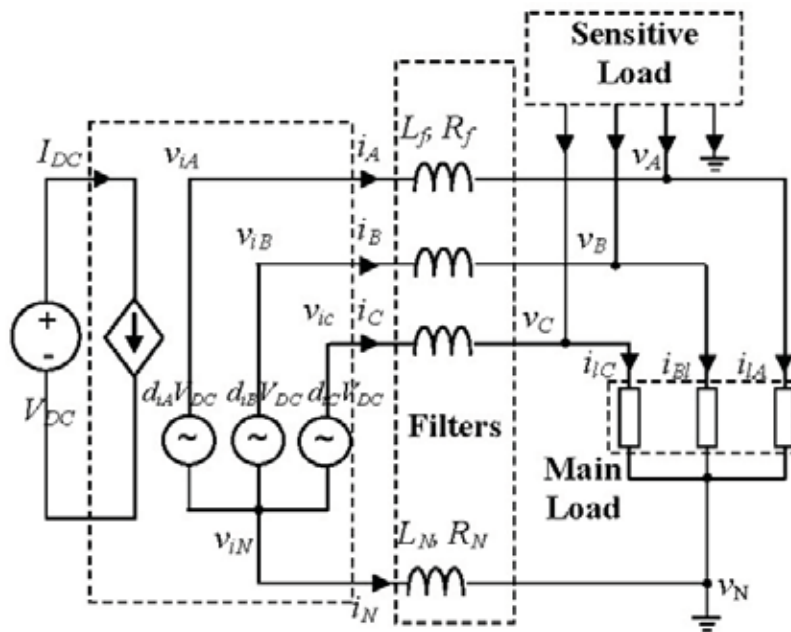

**Fig. 1:** Model of the three-leg VSI and the associated filters.

**System Configuration:**

The single-line diagram of a distribution system including the UPS is shown in Fig. 2. For simplicity, it is supposed that the UPS is supplied from a battery with a dc voltage of  $V_{dc}$ . The load is supposed to be unbalanced and nonlinear. The load is connected at the far end of a feeder with an impedance of  $R + j\omega L$ , which is supplied by a source ( $v_s$ ). An LC filter is connected at the output of VSC, to eliminate switching harmonics. The inductance and the capacitance of which are denoted by  $L_f$  and  $C_p$ , respectively, while the resistance  $R_f$  imply the circuit losses. The PCC voltage is symbolized by  $v_r$ .

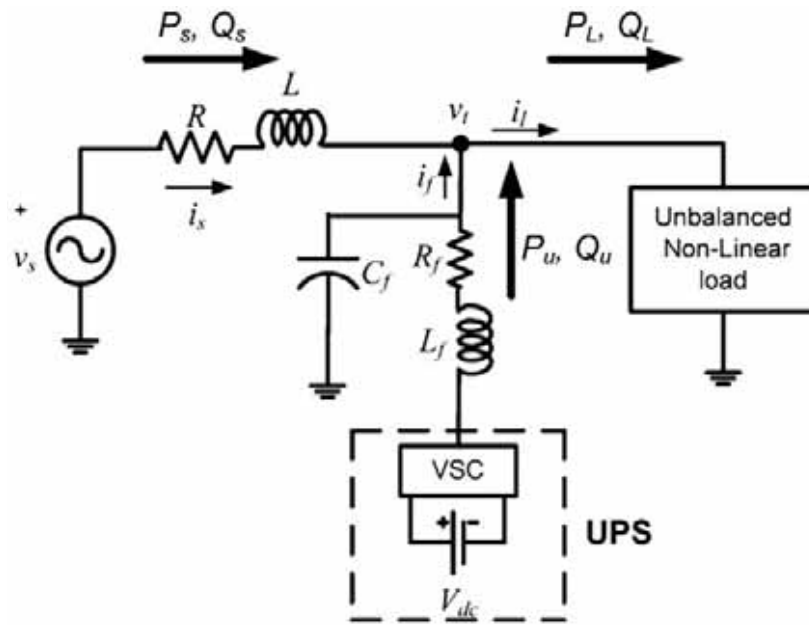

Fig. 2: Single-line diagram of the distribution system containing a UPS.

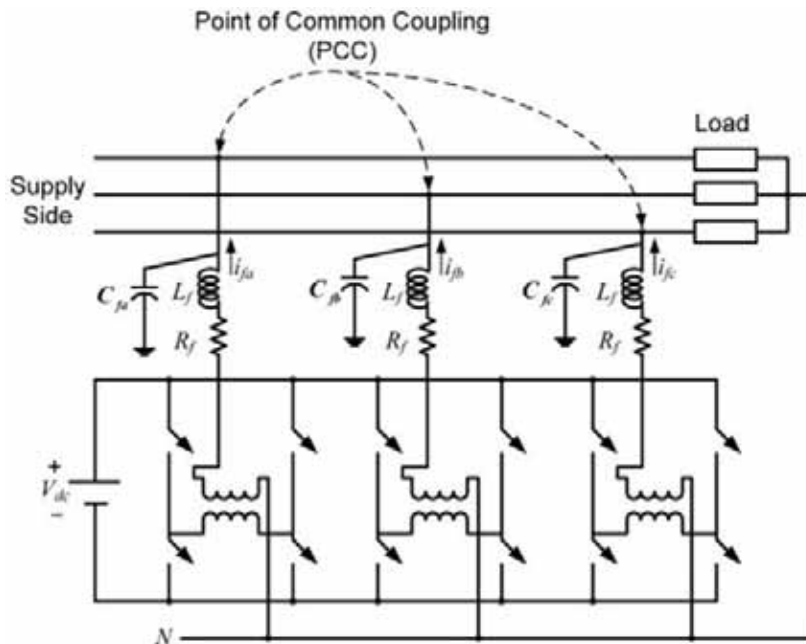

Fig. 3: UPS structure containing three VSCs that are supplied from a common dc source.

**The UPS Model:**

The model of the UPS in shown in Fig. 3. It comprises three H-bridge VSCs. All three VSCs are linked to common dc storage source  $V_{dc}$ . Each VSC is connected to network through single-phase transformer. The three single-phase transformers are used to prepare isolation. The LC filter for each phase made of Leakage inductance of transformer  $L_f$  and the filter capacitor  $C_f$ . All three transformers are connected in star and neutral point is connected to the neutral of the load or it could be grounded if neutral point of load is not attainable.

### **Control Strategies:**

The main purpose of this paper is to provide a balanced PCC voltage ( $v_i$ ) regardless of unbalance and distortion in the load currents. We control the voltage of the PCC (load) to the nominal value even when there is a unbalance in the load voltage. Therefore the reference for Fuzzy controller contains pre-specified voltage requirements, to control modulation index in voltage source converter (VSC), which is used in an uninterrupted power supply (UPS) application. The VSC then will have to track this reference voltage ( $V_{ref}$ ) in order to achieve the desired performance.

The linear control theory uses a mathematical model of a plant and some specifications of the anticipated behavior in close loop to design a controller. These plans are favorably used and have a good behavior in systems that can be supposed as linear in specific range of their operation, under determined conditions. The method of root-locus design was tried in the linear control design, and would not be deal with profundity in this paper, because of acceptable results have not been achieved, due to the difficulty to achieve a mathematical model as in numerous nonlinear or unknown systems, or in some cases, system does not have constant parameters or has interdependence with others parameters. In these cases, the linear control strategies could be limit in its design and performance. These reasons cause that the human knowledge adds various types of information and mix different control strategies that cannot be added in an analytical control law and do not need an accurate mathematical model. The Knowledge-based fuzzy control uses the experience and the knowledge of a proficient about the system behavior. A kind of Knowledge-based fuzzy control is the rule-based fuzzy control, where the human knowledge is approached by means of linguistic fuzzy rules in the form *if-then*, which describes the control action in a special condition of the system. Due to the nonlinear behavior exhibited by the converter, designing a linear control is not successful. By knowing the advantages of the fuzzy control, described before, a nonlinear fuzzy control might be desirable to control the PCC voltage, by controlling modulation index ( $m$ ) of voltage source converter (VSC). The control proposed for the controller is a Mamdani controller, since it is usually used as feedback controller because the rule base represents a static mapping between the preceding and the consequent variables. For controlling voltage to a request reference in a fuzzy controller, the Fuzzy Inference System (FIS) uses the error  $e=V_0-V_{ref}$  and error deviation (where  $V_0$  is the voltage take up or given for the load and  $V_{ref}$  is the request value of the voltage in the load) as inputs, and the change in the modulation index ( $m$ ) of the PWM as output.

The fuzzy logic controller unlike conventional controllers does not require a mathematical model of the system that should be controlled. However, a comprehending of the system and the control requirements, is necessary. The fuzzy controller designer must clarify how the information is processed (control strategy and decision), and information flows out of the system (solution/output variable). The fuzzy logic controller consists of three basic block: 1)Fuzzification; 2)Inference Mechanism; 3)Defuzzification

### **Fuzzification:**

The fuzzy logic controller requires that each control variables which define the control surface be described in fuzzy set symbols using linguistic rules. Seven fuzzy subsets have been used in this paper, these are: PB(positive big),PM(positive medium), PS(positive small), ZE(zero), NS(negative small), NM(negative medium) and NB(negative big). For each of these fuzzy sets, Gaussian membership function (MF) has been used. These membership functions are shown in Fig. 4,5,6. These membership functions are used to decompose each system variables into fuzzy domain. The membership functions symbolize the extent that which variable is a member of a particular rule. This procedure of converting input/output variables to linguistic rules is designated as Fuzzification that is performed using the rule bases shown in below. The control rules are constructed based on the characteristics of the step response. For example, if the output is falling far away from the set point, a large control signal that pushes the output toward the set point is awaited, since a small control signal is required when the output is near and approaching the set point.

### **Inference Mechanism:**

The behavior of the control surface which explains the input and output variables of the system, is managed by a set of rules. A characteristic of rules would be: If(*fuzzy suggestion*) Then (*fuzzy suggestion*) Where the fuzzy suggestion is of the type " $x$  is  $y$ " or " $x$  is not  $y$ ",  $x$  being a scalar variable and  $y$  is a fuzzy set associated with that variable. These rules are used to decide the proper control action. When a set of input variables are read, each of the rules that has any grade of truth (a nonzero value of membership grade) in its premises is fired and cause to creating of the control surface by properly adapting it. When all the rules are fired, the resulting control surface, described as a fuzzy set to represent the controllers output. These rules used to create a fuzzy set that semantically represents the concept associated with the rule. To have a smooth, stable

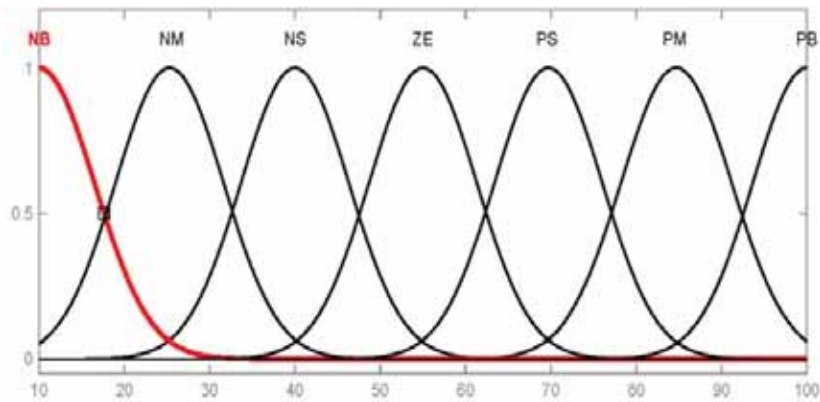

**Fig. 4:** Membership Function of error  $e(t)$

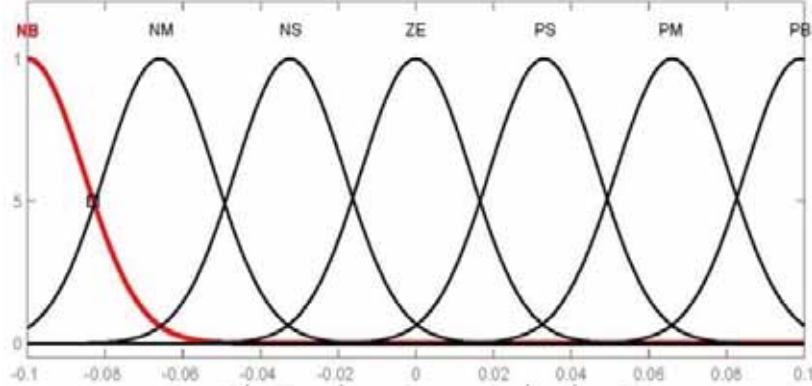

**Fig. 5:** Membership Function of error derivative  $\dot{e}(t)$

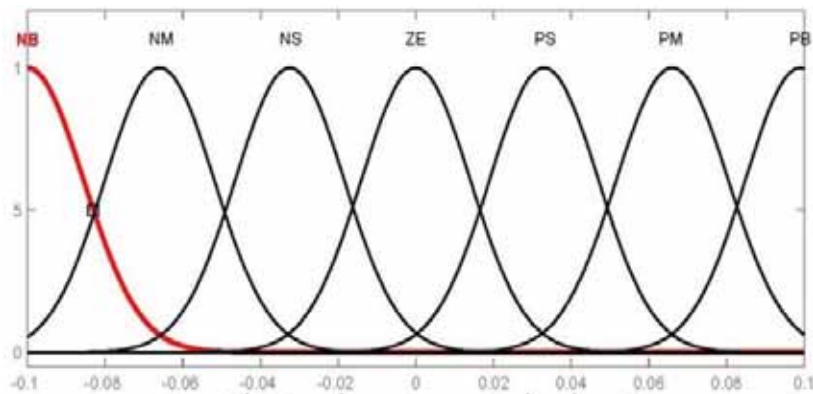

**Fig.6.** Membership Function of output (modulation index)

control surface, an overlap between adjoining rules is provided such that the sum of the vertical points of overlap should never be greater than one. In the proposed controller the error  $e=V_0-V_{ref}$  and error deviation are fuzzified and described as fuzzy sets. The rule bases that can be used in this paper are shown in table1.

Defuzzification: the fuzzy set that depicting the controller output in linguistic rules, has to be transformed into a feasible solution variable before it can be used to control the system. This is obtained by using a Defuzzification. Various methods of Defuzzification are available. The most prevalently used methods are **a)** Mean of Maxima (MOM) and **b)** Center of Area (COA). Most control applications use the COA method. This method calculates the center of gravity of the final fuzzy space and products a result which is sensitive to all the rules performed. Hence the results tend to move smoothly across the control surface.

**Table1:** fuzzy control rules

$\acute{e}/c$	NB	NM	NS	ZE	PS	PM	PB
NB	NB	NB	NB	NM	NS	NS	ZE
NM	NB	NM	NM	NM	NS	ZE	PS
NS	NB	NM	NS	NS	ZE	PS	PM
ZE	NB	NM	NS	ZE	PS	PM	PB
PS	NM	NS	ZE	PS	PS	PM	PB
PM	NS	ZE	PS	PM	PM	PM	PB
PB	ZE	PS	PS	PM	PB	PB	PB

**Simulation Results:**

In this work, the effectiveness of the proposed fuzzy controller has been validated on system shown in Fig. 2. The PCC reactive power can be tracked using the fuzzy controller described in Section IV.

Application of proposed controller is illustrated with the help of the following example where a comparison is also made with the conventional PI controller.

**Example1:**

Consider the system shown in Fig. 2. It is assumed that the source voltage  $v_s$  is balanced and has a magnitude of 200V rms, the load is an unbalanced nonlinear load, whose unbalanced RC components are:

$$Z_{ia} = 10-j26.52, Z_{ib} = 20-j13.26, Z_{ic} = 30-j6.63$$

Where the subscripts a, b and c denote the three phases. The feeder impedance is  $R + j\omega L = 0.01+j0.35$ . The UPS parameter are  $V_{dc} = 400V, L_f = 2mH$  and  $C_f = 50\mu F$ . The UPS is connected to grid at time  $t = 0$  where it is required to maintain the PCC voltage at 200V rms. At  $t = 0.2$  s, one more balanced three-phase load with  $Z_{ia} = 10-j26.52, Z_{ib} = 20-j26.52, Z_{ic} = 30-j26.52$  is connected. The additional load is turned off at  $t = 0.3$  s. The PCC voltage is shown in Fig. 7. It can be seen that the voltage, track the reference ( $V_{ref}=200$ ) during this unbalance in voltage of PCC. The reactive power flowing through the circuit is shown in Fig. 8. The active power flowing through the circuit is shown in Fig. 9, and the load current is shown in Fig10. To compare the results obtained with the fuzzy controller, the same test is repeated with the conventional PI controller(Fig11, Fig12, Fig13, and Fig14).

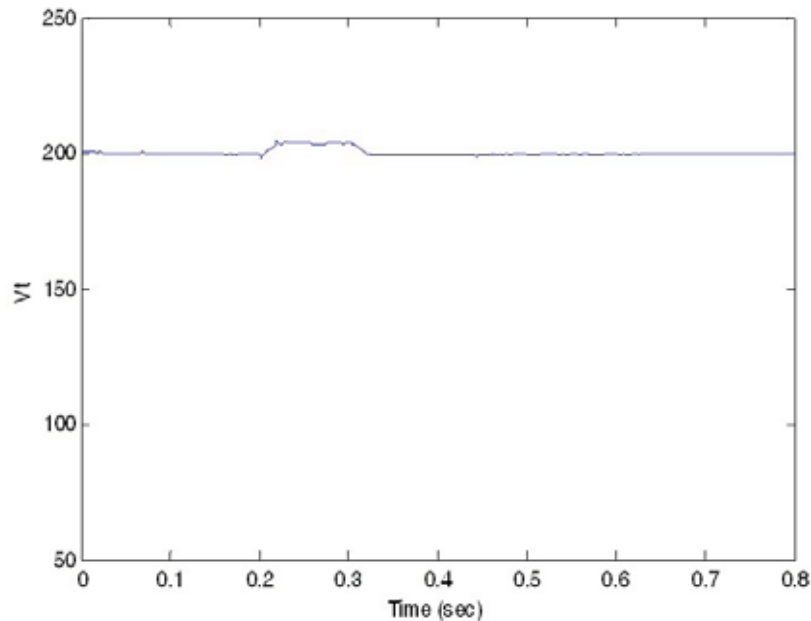

**Fig. 7:** The PCC voltage through fuzzy controller with RC load

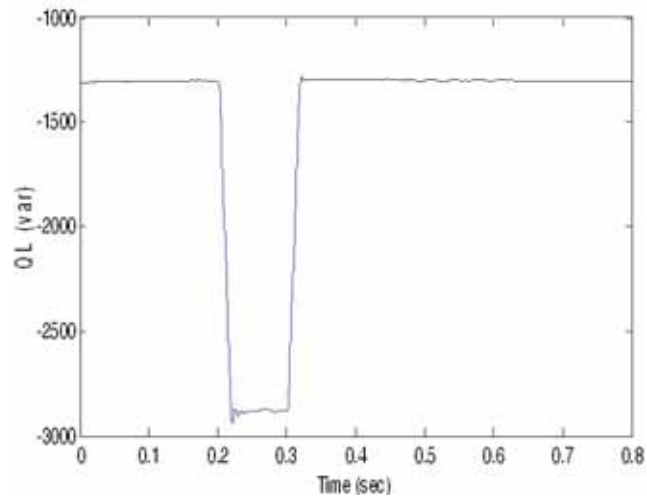

**Fig. 8:** Reactive power flowing through the circuit with fuzzy controller with RC load.

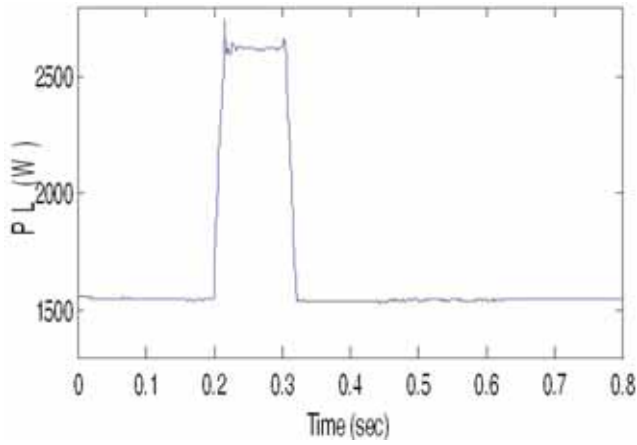

**Fig. 9:** Active power flowing through the circuit with fuzzy controller with RC load.

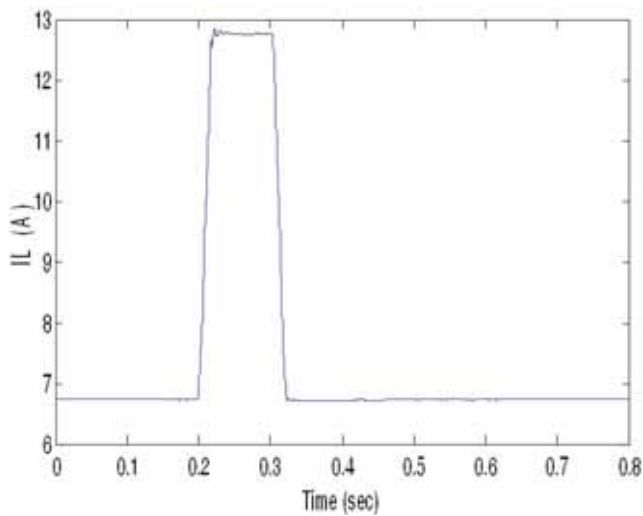

**Fig. 10:** The Load current through fuzzy controller with RC load.

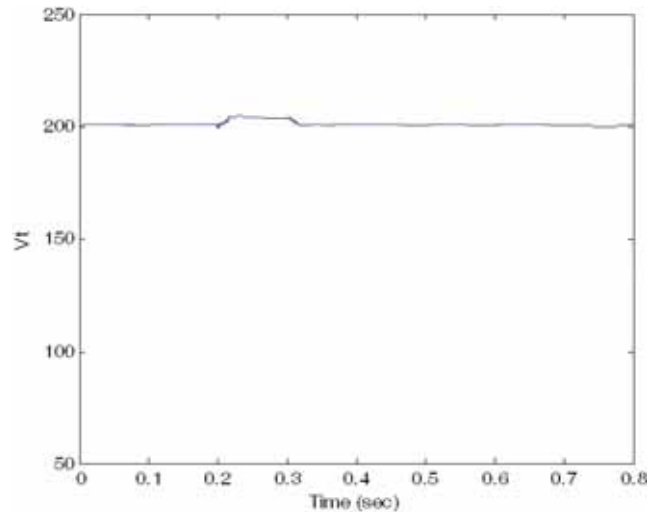

**Fig. 11:** The PCC voltage through conventional PI controller with RC load.

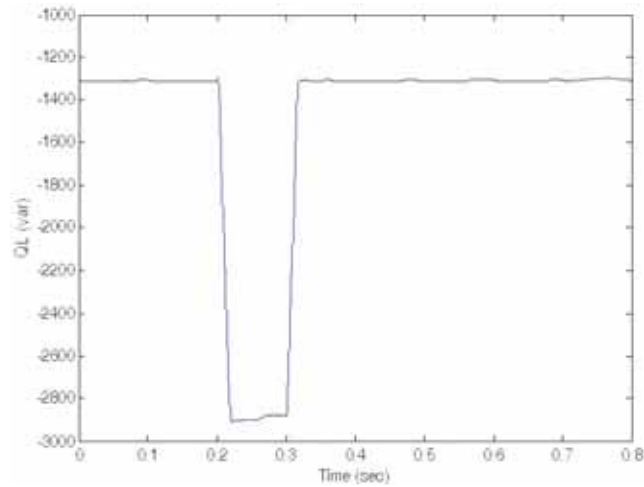

**Fig. 12:** Reactive power flowing through the circuit with conventional PI controller with RC load.

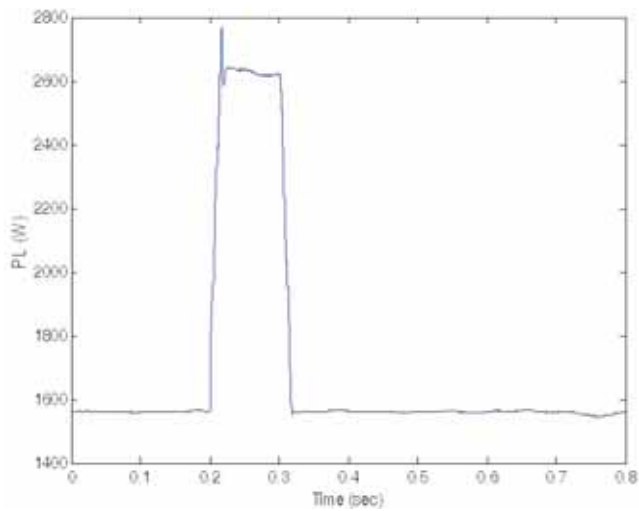

**Fig. 13:** Active power flowing through the circuit with conventional PI controller with RC load.

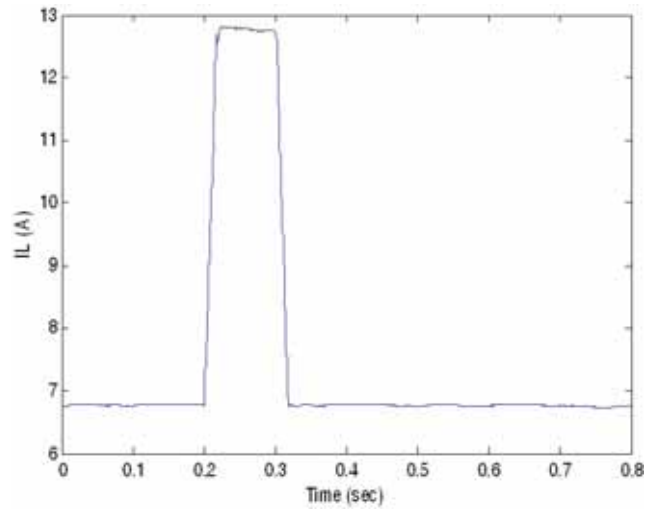

**Fig. 14:** The Load current through conventional PI controller with RC load.

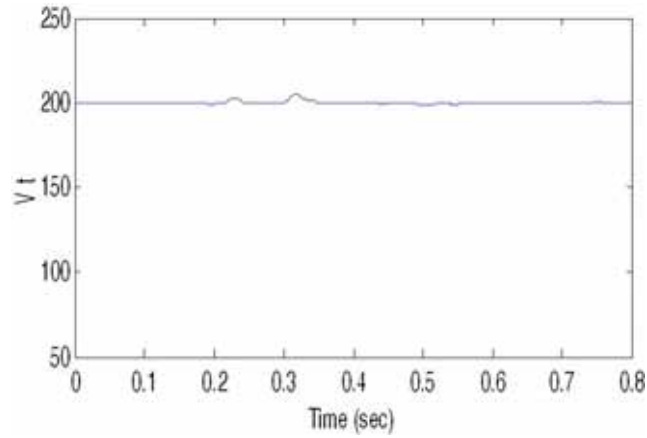

**Fig. 15:** The PCC voltage through fuzzy controller with RL load

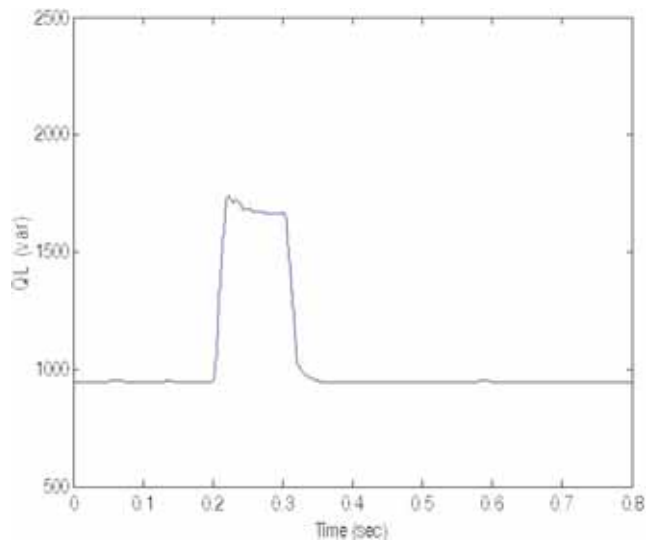

**Fig. 16:** Reactive power flowing through the circuit with fuzzy controller with RL load

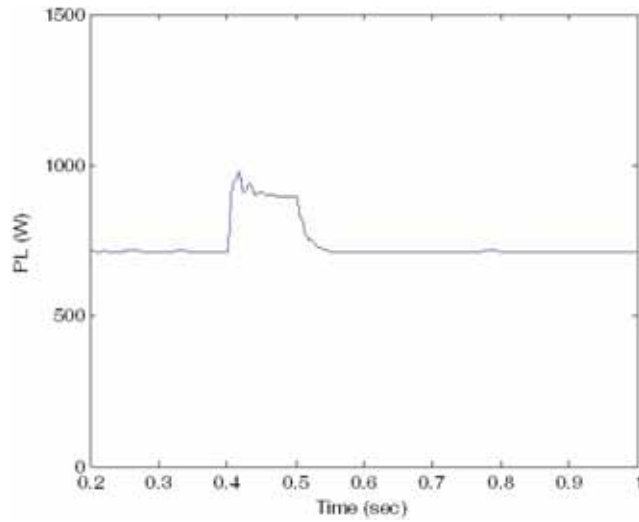

**Fig. 17:** Active power flowing through the circuit with fuzzy controller with RL load

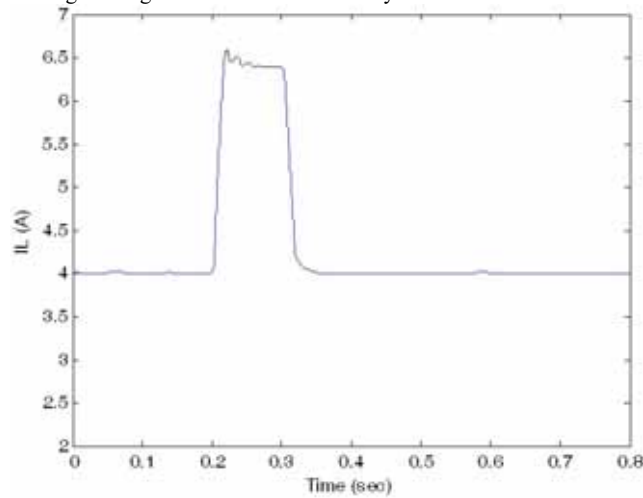

**Fig. 18:** The Load current through fuzzy controller with RL load

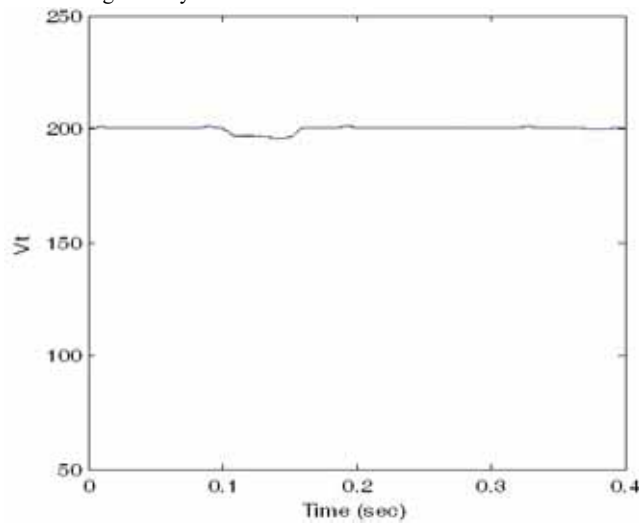

**Fig. 19:** The PCC voltage through conventional PI controller with RL load

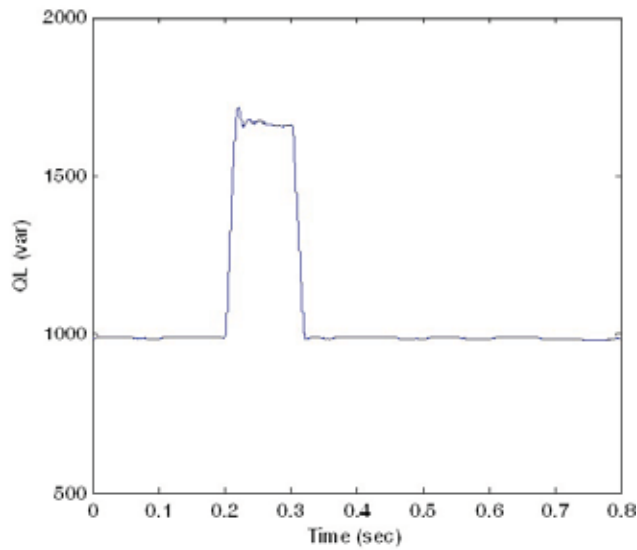

Fig. 20: Reactive power flowing through the circuit with conventional PI controller with RL load

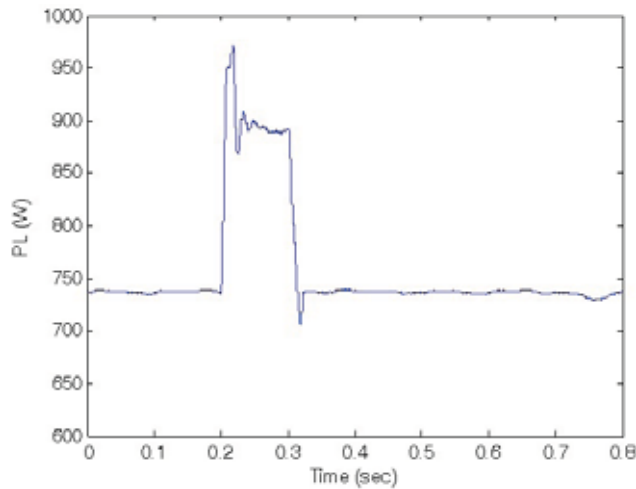

Fig. 21: Active power flowing through the circuit with conventional PI controller with RL load

**Example2:**

To investigate the behavior of the UPS controller at unbalanced RL load, we consider the same system as given in Example 1, whose unbalanced RL components are:

$$Z_{ia} = 10+j80, Z_{ib} = 20+j40, Z_{ic} = 30+j20$$

At  $t = 0.2$  s, one more balanced three-phase load with  $Z_{ia} = 10+j80, Z_{ib} = 20+j80, Z_{ic} = 30+j80$  is connected. The additional load is turned off at  $t = 0.3$  s. The PCC voltage is shown in Fig. 15. It can be seen that the voltage, track the reference ( $V_{ref}=200$ ) during this unbalance in voltage of PCC. The reactive power flowing through the circuit is shown in Fig. 16. The active power flowing through the circuit is shown in Fig. 17, and The load current is shown in Fig18. To compare the results obtained with the fuzzy controller, the same test is repeated with the conventional PI controller(Figs.19-22).

**Conclusions:**

In this paper we implement nonlinear Fuzzy controller which regulates the modulation index of voltage source converter (VSC),which is used in an uninterrupted power supply (UPS) application, to control Volt/Var in the grid. Since the PCC voltage is balanced, the current drawn from the source are regulated regardless

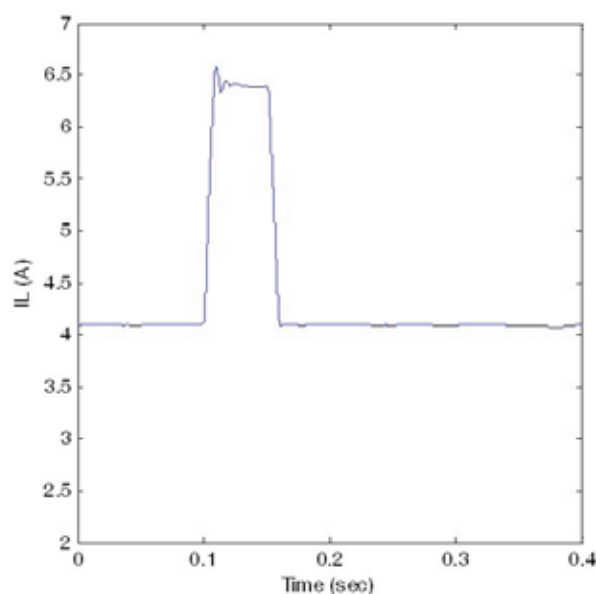

**Fig. 22:** The Load current through conventional PI controller with RL load.

of the nature of the load. The use of an LC filter with the UPS removes the effect of switching frequency components at PCC voltage. The UPS supply active power to a three-phase, four-wire distribution system. This convinced a full pliability to the grid to buy power from the UPS system depending on its cost and load requirement at any given time. From the simulation studies it has been found out that the performance of the proposed fuzzy controller, through wide range of operating condition such as harmonics, unbalancing and voltage sag/swell, is better than that obtained by the conventional PI controller.

## REFERENCES

- Andrija T. Saric, Milan S. Calovic and Vladimir C. Strezoski, 2003. "Fuzzy multi objective algorithm for multiple solution of distribution systems voltage control", *Electrical Power and Energy Systems*, 25: 145-153.
- Abdelouahab Bouafia, Fateh Krim and Jean-Paul Gaubert, 2009. "Design and implementation of high performance direct power control of three-phase PWM rectifier, via fuzzy and PI controller for output voltage regulation", *Energy Conversion and Management*, 50: 6-13.
- Al-Kandari, A.M., S.A. Soliman and R.A. Alammari, 2006. "Power quality analysis based on fuzzy estimation algorithm: Voltage flicker measurements", *Electrical Power and Energy Systems*, 28: 723-728.
- Akbar Rahideh, M. Gitizadeh and Abbas Rahideh, 2006. "Fuzzy logic in real time voltage/reactive power control in FARS regional electric network", *Electric Power Systems Research*, 76: 996-1002.
- Abdul-Rahman, K.H., S.M. Shahidehpour, M. Daneshdoost, 1995. "An approach to optimal var control with fuzzy reactive loads", *IEEE Transaction on power system*, 10(1).
- Bech, M.M., F. Blaabjerg and J.K. Pedersen, 2000. "Random modulation techniques with fixed switching frequency for three-phase power converters", *IEEE Trans. Power Electron*, 15: 753-761.
- Bin Yu and Liuchen Chang, 2005. "Improved predictive current controlled PWM for single-phase grid-connected voltage source inverters", *Power Electronics Specialists Conference, (PESC '05)*, pp: 231-236.
- Camblong, H., 2007. Member IEEE, I. Vechiu, and O. Curea, "An Innovative VSI Controller for the Generation of Balanced Voltage in Spite of the Presence of Unbalanced Loads", *Proceedings of the 2007 American Control Conference New York City, USA*.
- El-Barbari, S., W. Hofmann, 2000. "Digital Control of Four-Leg Inverter for Standalone Photovoltaic Systems with Unbalanced Load", presented at *IECON 2000, 26th Annual Conference of the IEEE Industrial Electronics Society, Nagoya*, 1: 729-734.
- Ho, B.M.T. and Henry Shu-Hung Chung, 2005. "An integrated inverter with maximum power tracking for grid-connected PV systems", *IEEE Trans on Power Electronics*, 20: 953-962.

Ilhan Kocaarslan and Ertugrul Cam, 2005. "Fuzzy logic controller in interconnected electrical power systems for load-frequency control", *Electrical Power and Energy Systems*, 27: 542-549.

Kojabadi, H.M., I.A. Bin Yu, Gadoura, Liuchen Chang and M. Ghribi, 2006. "A novel DSP-based current-controlled PWM strategy for single phase grid connected inverters", *IEEE Trans on Power Electronics*, 21: 985-993.

Perales, M.A., M.M. Prats, R. Portillo, J.L. Mora, J.I. Leon and L.G. Franquelo, 2003. "Three-dimensional space vector modulation in ABC coordinates for four-leg voltage source converters", *IEEE Power Electronics Letters*, 1(4).

Venkatesh, B., 2000. Member, IEEE, G. Sadasivam, and M. Abdullah Khan, *Member, IEEE*, "A New Optimal Reactive Power Scheduling Method for Loss Minimization and Voltage Stability Margin Maximization Using Successive Multi-Objective Fuzzy LP Technique", *IEEE Transaction On Power systems*, 15(2).

Vechiu, I., H. Camblong, G. Tapia, B. Dakyo and O. Curea, 2005. "Modelling and control of four-wire voltage source inverter under unbalanced voltage condition for hybrid power system applications", presented at the EPE 2005 Conference, Dresden.

Wen Zhang and Yutian Liu, 2008. "Multi objective reactive power and voltage control based on fuzzy optimization strategy and fuzzy adaptive particle swarm", *Electrical Power and Energy Systems*, 30: 525-532.

Xu Yan, Liu Qing, Wang Fei and Wang Zengping, 2005. "A Novel Method on Substation Reactive Power Control with the Fuzzy Logic Method", *Tencon 21-24 IEEE Region*, 10: 1-5.

Yadaiah, N., A. Ganga Dinesh Kumara and J.L. Bhattacharya, 2004. "Fuzzy based coordinated controller for power system stability and voltage regulation", *Electric Power Systems Research*, 69: 169-177.