

Compensation of Different Types of Voltage Sags in Low Voltage Distribution System Using Dynamic Voltage Restorer

¹Rosli Omar, ²N.A Rahim and ³Marizan Sulaiman

¹Faculty of Electrical Engineering, Universiti Teknikal Malaysia Melaka, Locked Bag 1752, Pejabat Pos Durian Tunggal, 76109, Durian Tunggal, Melaka, MALAYSIA

²UMPEDAC, Faculty Of Engineering, University Of Malaya, 50600 Kuala Lumpur Malaysia.

³Faculty of Electrical, Universiti Teknikal Malaysia Melaka, Karung Berkunci 1752, Pejabat Pos Durian Tunggal, 76109, Durian Tunggal Melaka.

Abstract: The main problems of the voltage sag in low voltage distribution systems due to sensitive loads. Voltage sags can caused malfunction in the distribution system. In order to protect voltage sags in the network a device which called Dynamic Voltage Restorer (DVR) is installed between the incoming supply and the sensitive loads. It is found that the DVR is an effective solution for the protection of sensitive loads from voltages sags. This paper discusses a DVR operation as a protection device, analysis of its controller and the active power injection requirements in the system. In this paper also highlights the different types of fault in both single phase and three phase fault. The experimental results validate the effectiveness of the device acts a protection scheme.

Key words: Dynamic voltage restorer (DVR), voltage sag, power injected, low voltage, custom device

INTRODUCTION

There are many methods been used to protect equipment in low voltage distribution system from malfunction due to voltage sags. The voltage sags as defined by IEEE Standard 1159, IEEE Recommended Practice for Monitoring Electric Power Quality, is “a decrease in RMS voltage or current at the power frequency for durations from 0.5 cycles to 1 minute, reported as the remaining voltage”. Typical values are between 0.1 p.u. and 0.9 p.u., and typical fault clearing times range from three to thirty cycles depending on the fault current magnitude and the type of over current detection and interruption (IEEE Standards Board, 1995).

Voltage sags are due to short duration increases in current in low voltage distribution system. The main factor causes of voltage sags are faults, motor starting, and transformer energizing. Typical end-use equipment sensitive to voltage sags are: computers, programmable logic controllers, controller power supplies, motor starter contactors, control relays and adjustable speed drives. The most common mitigation method remains the installation of additional equipment between the power system and the equipment, either directly with the equipment terminals or at the customer-utility interface. The uninterruptable power supply (UPS) has traditionally been the method of choice for small power, single-phase equipment. For large equipment several methods are in use and under development; one of which is the dynamic series compensator, also known under the name “dynamic voltage restorer” or DVR (IEEE Standards Board, 1995; Sabin, D., 1996).

This paper studies an introduction to DVR and explains it’s functions and also presents the active power injection requirements for designing of a dynamic voltage restorer in order to protect sensitive loads from any disturbances.

2. Dynamic Voltage Restorer Operations:

A DVR, Dynamic Voltage Restorer is a distribution voltage DC-to-AC solid-state switching converter that injects three single phase AC output voltages in series with the distribution feeder and in synchronicity with the voltages of the distribution system. By injecting voltages of controllable amplitude, phase angle, and frequency (harmonic) into the distribution feeder in instantaneous real time via a series-injection transformer, the DVR can restore the quality of voltage at its load side terminals when the quality of the source side

Corresponding Author: Rosli Omar, Faculty of Electrical Engineering, Universiti Teknikal Malaysia Melaka, Locked Bag 1752, Pejabat Pos Durian Tunggal, 76109, Durian Tunggal, Melaka, Malaysia.
E-mail:omarrosli@yahoo.com.

terminal voltage is distorted due to sensitive loads. Generally the DVR comprises of three important parts (Zhang, L.D., M.H.J. Bollen, 1998):

- Voltage Source Converter (VSC)
- DC energy storage
- Control system

Figure1 shows the basic block diagram of a DVR for single-phase representation.

A. Basic Principle:

The basic idea of a DVR is to inject the missing voltage cycles into the system through series injection transformer whenever voltage sags are present in the system supply voltage. As a consequence, sag is unseen by the loads. During normal operation, the capacitor receives energy from the main supply source. When voltage dip or sags are detected, the capacitor delivers dc supply to the inverter. The inverter ensures that only the missing voltage is injected to the transformer.

A relatively small capacitor is present on dc side of the PWM solid state inverter, and the voltage over this capacitor is kept constant by exchanging energy with the energy storage reservoir. The required output voltage is obtained by using pulse-width modulation switching pattern. As the controller will have to supply active as well as reactive power, some kind of energy storage is needed. In the DVRs that are commercially available now, large capacitors are used as a source of energy (Sng, E.K.K., 2004). Other potential sources are being considered are (Zhang, L.D., M.H.J. Bollen, 1998): battery banks, superconducting coils, and flywheels.

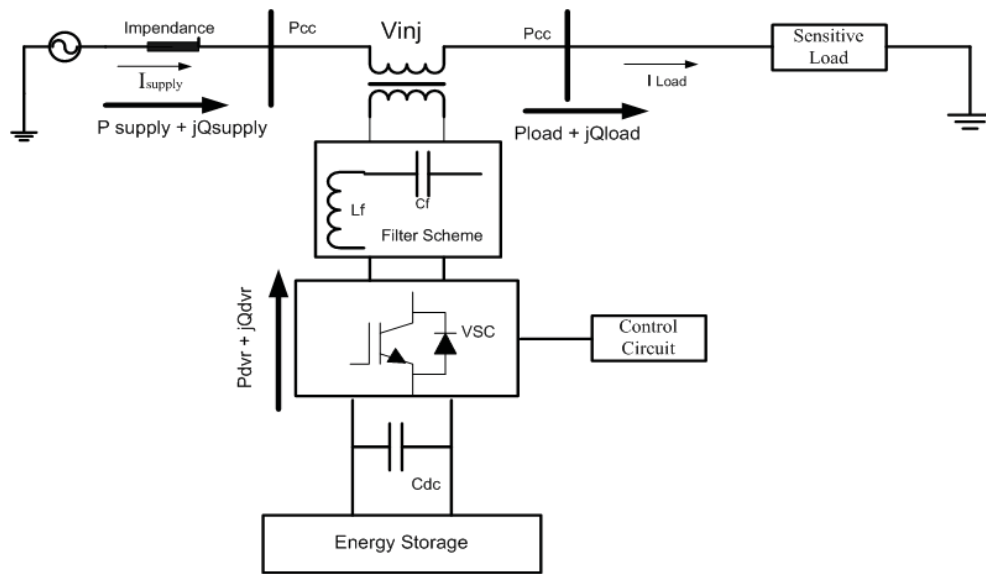

Fig. 1: Typical DVR circuit topology (single-phase representation).

B. Control System of a DVR:

The aim of the control scheme is to maintain constant voltage magnitude at the point where a sensitive load is connected under system disturbances. The control system only measures the r.m.s voltage at the load point, i.e., no reactive power measurements are required. The VSC switching strategy is based on a space vector PWM technique which offers simplicity and good response. The control of DVR is very important and it involves detection of voltage sags (start, end and depth of the voltage sag) by appropriate detection algorithms which work in real time. The voltage sags can last from a few milliseconds to a few cycles, with typical depths ranging from 0.9 pu to 0.5 pu of a 1-pu nominal (Zhan, V.K. 2001).

3. A Conceptual Of the DVR Control with Symmetrical Voltage Sags Controller:

Control Strategy:

The concept of control strategies for a DVR compensating without any phase-angle jump is illustrated in

Figure 2. Figure 2 shows the flow of active and reactive power with a DVR inserted. The DVR controller as shown in Figure 2 concept consists of load side voltage (V_{load}), grid or supply voltage (V_{supply}) and injection voltage from transformer (V_{inj}). The relationship between load voltage, injection voltage and supply voltage can be described as:

$$\overline{V_{load}} = \overline{V_{inj}} + \overline{V_{supply}} \tag{1}$$

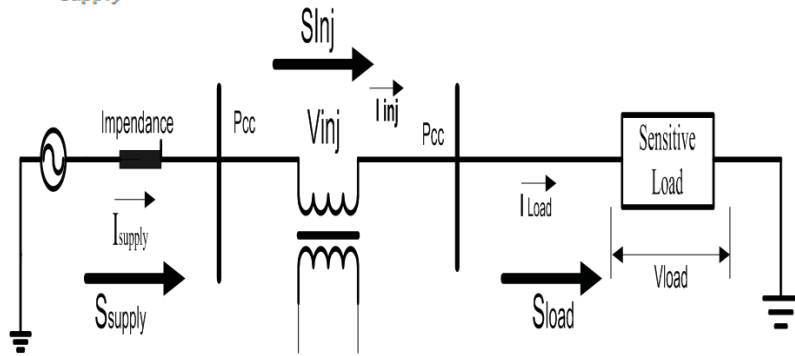

Fig. 2: Circuit diagram model of power system, controller and load.

The load voltage is considered maintained at 1 p.u without any phase angle

$$\overline{V_{load}} = |V| \angle \beta = 1 \tag{2}$$

The voltage during sag, V_{inj} with magnitude V and phase angle α

$$\left. \begin{aligned} \overline{V_{inj}} &= |V| \angle \alpha \\ \overline{V_{inj}} &= V(\cos \alpha + j \sin \alpha) \end{aligned} \right\} \tag{3}$$

The load current is equal to 1 pu, with a lagging power factor, $\cos \beta$

$$\left. \begin{aligned} \overline{I_{load}} &= |I_{load}| \angle -\beta \\ \overline{I_{load}} &= I_{load} [\cos \beta - j \sin \beta] \end{aligned} \right\} \tag{4}$$

The absorbed apparent power for S_{supply} , S_{inj} and S_{load} can be expressed as:

$$\left. \begin{aligned} S_{supply} &= P_{supply} + jQ_{supply} \\ S_{inj} &= P_{inj} + jQ_{inj} \\ S_{load} &= P_{load} + jQ_{load} \end{aligned} \right\} \tag{5}$$

The value of the injected power depends on the load power factor and the phase jump.

$$P_{inj} = \sqrt{3} |V_{inj}| |I_{load}| \cos(\beta_{load} + \alpha_{inj}) \tag{6}$$

From equation (5) the active power absorbed by the load is calculated as:

$$P_{load} = V_{load} I_{load} \cos \beta \tag{7}$$

In case of $V_{load} = 1$ and $I_{load} = 1$ therefore;

$$P_{Load} = 1 \quad (8)$$

From equation (1) and (2), the voltage injected by the controller can be determined as:

$$\overline{V}_{supply} = 1 - \overline{V}_{inj} \quad (9)$$

The current through the controller equals the load current:

$$|I_{load}| = |I_{supply}| = (\cos \beta - j \sin \beta) \quad (10)$$

The complex power injected by the controller is obtained from (9) and (10):

$$\overline{S}_{supply} = \left(1 - \overline{V}_{DVR} \right) \quad (11)$$

The active power injected to the load is calculated as:

$$P_{supply} = \sqrt{3} |V_{inj}| |I_{load}| (\cos \beta_{load}) \quad (12)$$

The power factor of the load determines how much power from the supply can be increased. The increase in active power ΔP is calculated as (Bollen, M.H.J., 2000):

$$\Delta P = P_{supply \max} - P_{supply \text{ pre-sag}}$$

$$\Delta P = P_{supply} = \sqrt{3} |V_{supply}| |I_{load}| \times (\cos(\beta_{load})) \quad (13)$$

4. Single Line Of Voltage Sag In Low Voltage Distribution System:

Figure 3, where the magnitude and phase of the faulted voltage sag during the sag at the point of common coupling (PCC) are determined by the fault and supply impedances using the equation:

$$V_{sag} = \frac{Z_F}{Z_F + Z_s} \quad (14)$$

Where;

\overline{Z}_F is the impedance between the fault and the point-of-common coupling (pcc) of the fault and the load.

\overline{Z}_s is the source impedance at the pcc, the pre-event voltage is considered equal to 1 pu, and all load is assumed to be of the constant-impedance type (Bollen, M.H.J., 1999; Vilathgamuwa, M., 2002).

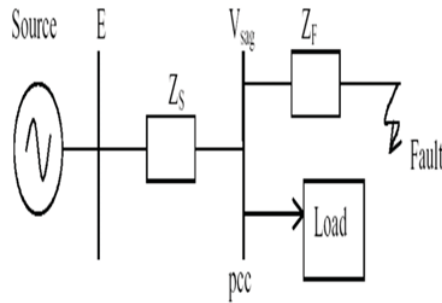

Fig. 3: A simple radial circuit of Voltage Sag.

$$V_{sag} = \frac{\mu}{\mu + e^{j\phi}} \tag{15}$$

Where $\mu = \left| \frac{Z_F}{Z_S} \right|$ and $\phi = \arg \left\{ \frac{Z_F}{Z_S} \right\}$

The voltage-divider model gives the so-called “characteristic voltage” for the voltages in the three phases. The model can be applied directly to study the effect of voltage sags on three-phase equipment (Vilathgamuwa, M., 2002; Li, B.H., 2001; Chan, K., 1998).

A. Three-Phase Unbalance Voltage Sag:

Due to different kinds of faults in power systems, different types of voltage sag can be produced most faults in power systems are single phase or three phases. Different types of faults lead to different types of voltage sags. Normally, voltage sag is characterized by a magnitude and duration. In some cases phase-angle jumps are also included. Voltage sags are divided in to seven groups as type A, B, C, D, E, F and G as shown in table (1).Type A is symmetrical and the other types are known as unsymmetrical voltage sag.

Balance Voltage Sags:

Balance voltage sags are due to three phases and three phase to ground faults. All three-phase voltage magnitudes are equal and lower than the sag threshold with no phase shift.

Table 1: The equations of different voltage sags (IEEE Standards Board, 1995)

TYPE A	TYPE B
$\bar{V}_a = V$	$\bar{V}_a = V$
$\bar{V}_b = -\frac{1}{2}V - \frac{1}{2}jV\sqrt{3}$	$\bar{V}_b = -\frac{1}{2}V - \frac{1}{2}j\sqrt{3}$
$\bar{V}_c = -\frac{1}{2}V + \frac{1}{2}jV\sqrt{3}$	$\bar{V}_c = -\frac{1}{2}V + \frac{1}{2}j\sqrt{3}$
TYPE C	TYPE D
$\bar{V}_a = 1$	$\bar{V}_a = V$
$\bar{V}_b = -\frac{1}{2}V - \frac{1}{2}jV\sqrt{3}$	$\bar{V}_b = -\frac{1}{2}V - \frac{1}{2}j\sqrt{3}$
$\bar{V}_c = -\frac{1}{2}V + \frac{1}{2}jV\sqrt{3}$	$\bar{V}_c = -\frac{1}{2}V + \frac{1}{2}j\sqrt{3}$

Table 1: Continue

TYPE E	TYPE F
$\bar{V}_a = 1$	$\bar{V}_a = V$
$\bar{V}_b = -\frac{1}{2}V - \frac{1}{2}jV\sqrt{3}$	$\bar{V}_b = -\frac{1}{2}V - \frac{1}{2}j\left(\frac{2}{2} + \frac{1}{2}V\right)\sqrt{3}$
$\bar{V}_c = -\frac{1}{2}V + \frac{1}{2}jV\sqrt{3}$	$\bar{V}_b = -\frac{1}{2}V + \frac{1}{2}j\left(\frac{2}{2} + \frac{1}{2}V\right)\sqrt{3}$

TYPE G
$\bar{V}_a = \frac{2}{3} + \frac{1}{2}V$
$\bar{V}_b = -\frac{1}{2}\left(\frac{2}{3} + \frac{1}{2}V\right)V - \frac{1}{2}jV\sqrt{3}$
$\bar{V}_c = -\frac{1}{2}\left(\frac{2}{3} + \frac{1}{2}V\right)V + \frac{1}{2}jV\sqrt{3}$

5. Experimental Results:

A small scale prototype DVR has been built based on schematic in Figure 4, in order to verify the effectiveness of the DVR operation principles. The major parameters as shown in Table 2 the experimental results obtained are based on type A, B and E of voltage sags.

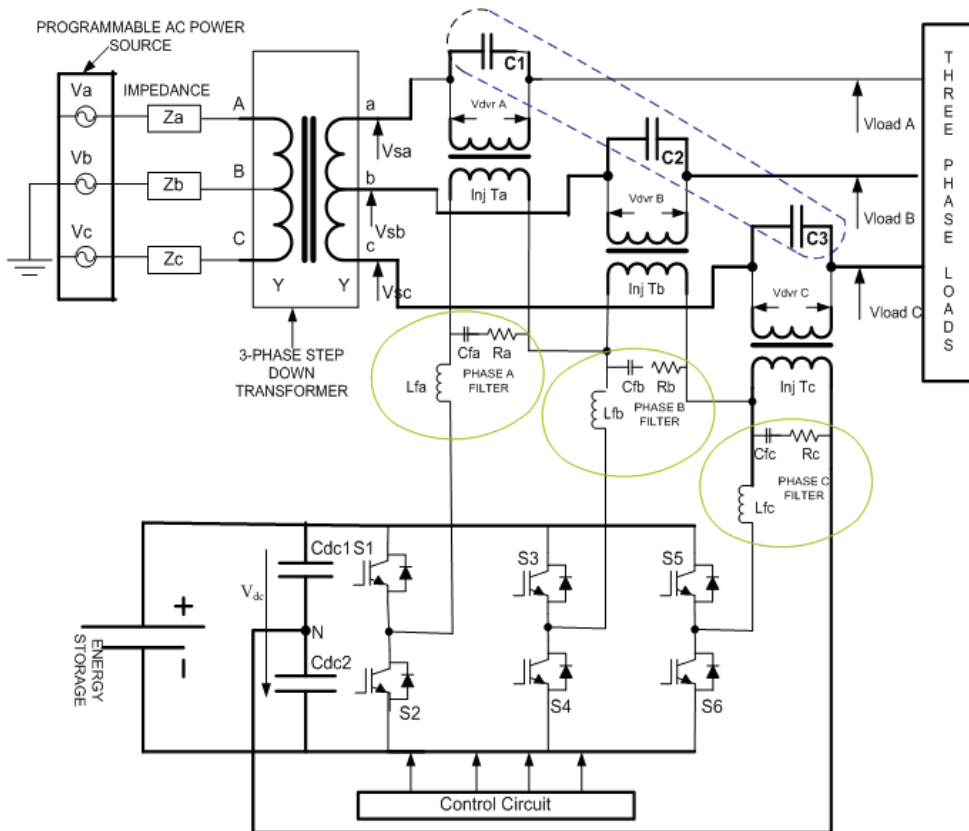

Fig. 4: The proposed new configuration of a DVR.

Table 1: Main specification of the DVR

PARAMETER	VALUE
Norminal grid voltage	230V (L-L)
Norminal load voltage	120V(L-L)
Maksimum series voltage Injection	100V(L-L)
Injection Transformer Ratio	1:1
Switching/sampling frequency	5 KHz
Max. inverter dc-bus voltage	100 V
Capacitor of dc- bus	26uF
Filter inductance	2.7mF
Filter capacitance	50uf

The prototype is rated to protect a 5KVA load a 40% voltage sags. Balanced voltage sag is created immediately after a fault as shown in Figure 5(a). The performance during 40% balance voltage sag is illustrated in Figure 5(a). Figure 5(b) shows the injection voltages produced by the DVR in order to inject missing voltages due to balanced fault from the supply voltages. Restoration voltages on the loads are shown in Figure 5(c).

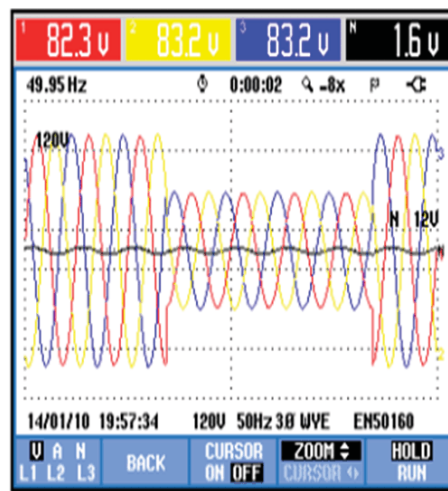

Fig. 5(a): Three phase fault Supply Voltages.

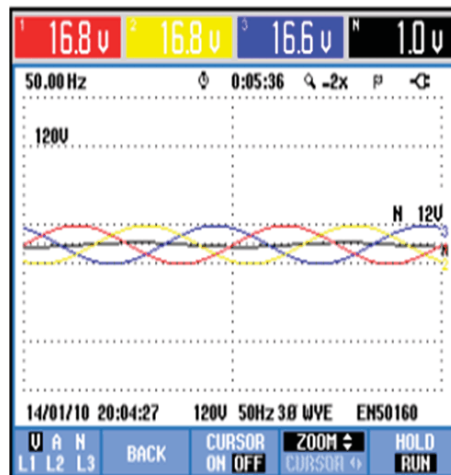

Fig. 5(b): Injection Voltage by DVR.

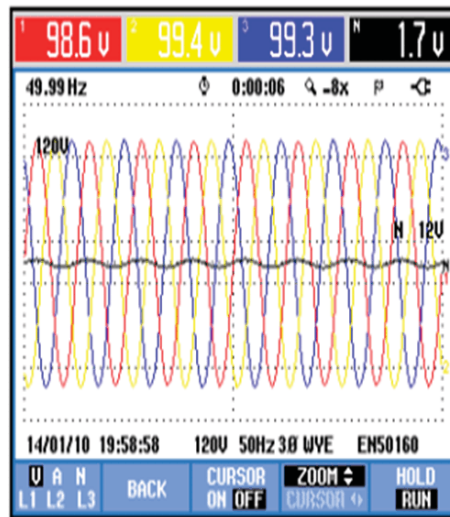

Fig. 5(c): Load Voltages Restoration.

Figure 6(a) shows experimental waveforms for the source voltages based on type B of voltage sags. One phase voltage magnitude is lower than two other phase voltage. Figure 6(b) shows the DVR compensated for the type B of voltage sags. Load terminal voltages are restored through the compensation by DVR. As can be seen from Figure 6(c), the load voltage is kept at the nominal value with the help of the DVR. Next, the performance of DVR for two phases to ground fault is also investigated. Figure 7(a) shows the series of voltages components for unbalanced conditions two phase to ground fault. Similar to the case of voltage sag for this type, the DVR reacts very fast to inject the appropriate voltage in order to correct the supply voltage as shown in Figure 7(b). The DVR load voltages are shown in figure 7(b). From the results, it shows that the sagged load terminal voltage is restored and helps to maintain a balanced and constant load voltage.

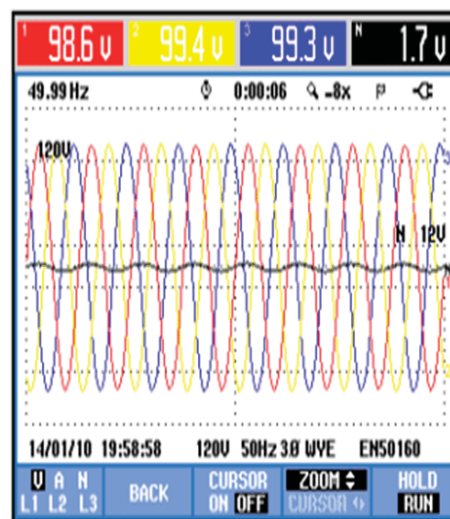

Fig. 6(a): Single phase fault Supply Voltages.

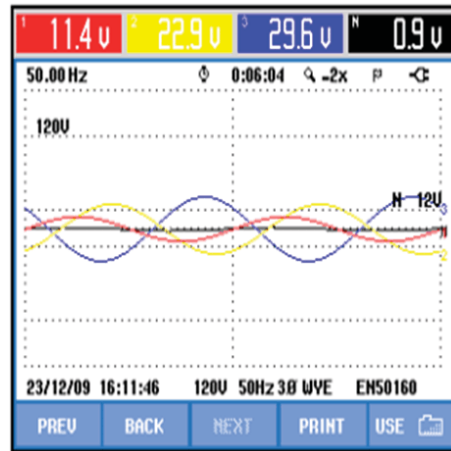

Fig. 6(b): Injection Voltages by DVR.

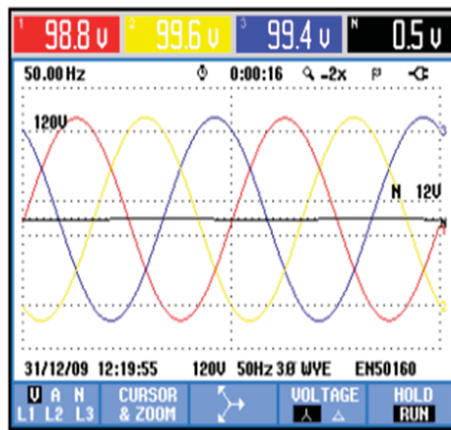

Fig. 6(c): Load Voltages Restoration.

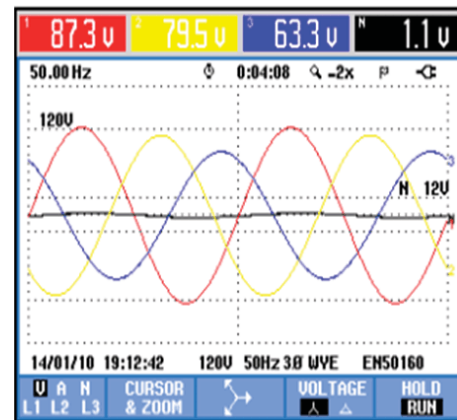

Fig. 7(a): Two phases fault Supply Voltages.

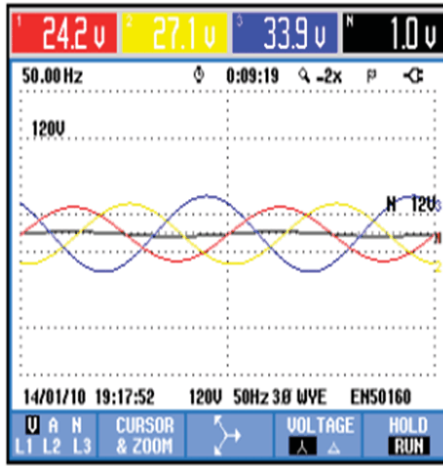

Fig 7(b): Injection Voltages by DVR.

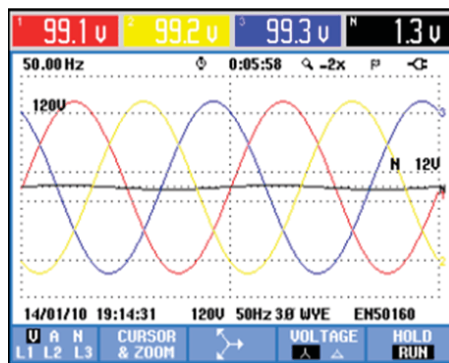

Fig. 7(c): Load Voltages restoration.

6. Conclusion:

This paper analyzes the compensation technique of a DVR for mitigating type A, B and E voltages sags in low voltage distribution system. The Dynamic Voltage Restorer (DVR) is a promising and effective device for power quality enhancement due to its quick response and high reliability. The conclusion is that the DVR is an effective apparatus to protect sensitive loads from short duration voltage sags. The DVR can be inserted both at the low voltage and medium voltage level. The proposed theory has been verified by an experimental DVR system that shows very good performance as predicted by the analysis.

It is shown that the active power requirements of a DVR depend on magnitude and phase-angle jump of the sag as well as on the power factor of the load.

ACKNOWLEDGMENT

The authors wish to thank UM and UTeM for providing grant under grant PS002/2009B for this project.

REFERENCES

- Bollen, M.H.J., 2000. Voltage, power and current ratings of series voltage controllers, IEEE Conference 2000.
- Bollen, M.H.J., 1999. Understanding power quality problems: voltage sags and interruptions, New York, IEEE Press.

Chan, K., 1998. Technical and performance aspects of a dynamic voltage restorer. In IEE Half Day Colloquium on Dynamic Voltage Restorers-Replacing Those Missing Cycles, pp: 5/1-5/25.

IEEE Standards Board, 1995. "IEEE Std. 1159-1995", IEEE Recommended Practice for Monitoring Electric Power Quality". IEEE Inc. New York.

Li, B.H., S.S. Choi and D.M. Vilathgamuwa, 2001. Design considerations on the line-side filter used in the dynamic voltage restorer: IEE Proc. Generat. Transmission Distribut., 148: 1-7.

Sabin, D., 1996. "An assessment of distribution system power quality," Elect. Power Res. Inst., Palo Alto, CA, EPRI Final Rep. TR-106294-V2, vol. 2, Statistical Summary Report.

Sng, E.K.K., S.S. Choi and D.M. Vilathga-Muwa, 2004. Analysis of series compensation and DC-link voltage controls of a transformerless self-charging dynamic voltage restorer. IEEE Trans. Power Delivery, 19: 1511-1518.

Vilathgamuwa, M., A.A.D. Ranjith Perera and S.S. Choi, 2002. Ormance improvcmnt of the dynamic voltage restorer with closed-loop load voltage and current-mode control", IEEE Transactions on Power Electronics, 17(5): 824-834.

Zhan, V.K. Ramachandaramuthy, A. Arulampalam, C. Fitzer, Barnes, 2001. "Dynamic Voltage Restorer based on voltage space vector PWM control", Sixteenth Annual IEEE, Applied Power Electronics Exposition, 2001, APEC 2001, 2: 1301-1307.

Zhang, L.D., M.H.J. Bollen, 1998. Characteristics of voltage dips (sags) in power systems, IEEE Int. Conf. On Harmonics and Quality of Power (ICHQP), Athens, Greece.