



AENSI Journals

Australian Journal of Basic and Applied Sciences

Journal home page: www.ajbasweb.com



Performance of Power Amplifier with Different Matching Techniques for GPS Application

Maizatul Alice Meor Said, Mohamad Harris Misran, Azahari Salleh, Mohd Azlishah Othman, Mohd Muzafar Ismail, Hamzah Asyrani Sulaiman, Rosman Abd Rahim, Nur Alisa Ali, Norbayah Yusop, Ridza Azri Ramlee, Mai Mariam Mohamed Aminuddin

Centre for Telecommunication Research and Innovation (CeTRI), Faculty of Electronic and Computer Engineering, University Teknikal Malaysia Melaka (UTeM), Hang Tuah Jaya, 6100 Durian Tunggal, Melaka, Malaysia

ARTICLE INFO

Article history:

Received 25 September 2013

Received in revised form 19

November 2013

Accepted 22 November 2013

Available online 4 December 2013

Key words:

Power amplifier, GPS, Gain, AT 41533, matching technique.

ABSTRACT

A Power Amplifier (PA) is designed and optimized to have high efficiency, high output power compression, good return loss and high gain for driving a signal to the antenna without any distortion or losses. The objective was design the PA at GPS L1 frequency 1.575 GHz with at least 10dB gain. Analyze PA is based on type of matching which is stub element, quarter-wave element and lumped element. The entire requirement is determine using calculation and simulated by using AWR software.

© 2013 AENSI Publisher All rights reserved.

To Cite This Article: Maizatul Alice Meor Said, Mohamad Harris Misran, Azahari Salleh, Mohd Azlishah Othman, Mohd Muzafar Ismail, Hamzah Asyrani Sulaiman, Rosman Abd Rahim, Nur Alisa Ali, Norbayah Yusop, Ridza Azri Ramlee, Mai Mariam Mohamed Aminuddin. Performance of Power Amplifier With Different Matching Techniques for GPS Application., *Aust. J. Basic & Appl. Sci.*, 7(12): 206-212, 2013

INTRODUCTION

Global Positioning System (GPS) power amplifier (PA) is commonly used in wireless communication device to amplify that signal (RF signal) and provides a large version of the signal that may direct to an antenna. It's also required to amplify the wanted signal without distortions and without other impairments which would decrease the usefulness of the signal. Without power amplifier, the signal will attenuate itself through the transmission line and resulting receiver can't construct the original signal information.

In order to overcome the problem, PA with the ability to achieved high gain and high output power is placed in front of the transmitter to boost the signal high enough to ensure the receiver get all the signal information that it should received and loss can be avoided. This project basically is to design Power Amplifier at L1 frequency (1.575 GHz) and to achieve gain more than 10dB.

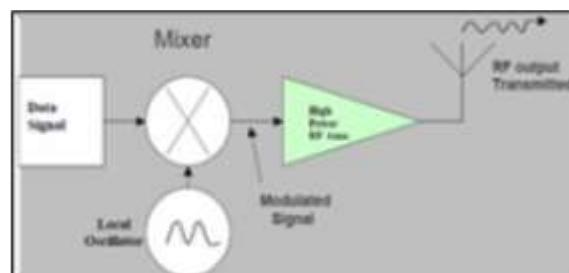

Fig. 1: Typical RF PA placement in transmitter system.

Each GPS satellite carries a cesium and/or rubidium atomic clock to provide timing information for the signals transmitted by the satellites. Internal clock correction is provided for each satellite clock. Each GPS satellite transmits two spread spectrums, L-band carrier signal. L1 signal with carrier frequency and an L2 signal with carrier frequency. These two frequencies are integral multiples and of a base frequency. The L1 signal from each satellite uses binary phase-shift keying (BPSK), modulated by two pseudorandom noise (PRN) codes in

Corresponding Author: Maizatul Alice Meor Said, Centre for Telecommunication Research and Innovation (CeTRI), Faculty of Electronic and Computer Engineering, UniversitiTeknikal Malaysia Melaka (UTeM), Hang Tuah Jaya, 6100 Durian Tunggal, Melaka, Malaysia.
E-mail: azlishah@utem.edu.my

phase quadrature, designated as the C/A-code and P-code. The L2 signal from each satellite is BPSK modulated by only the P-code (Larry Huffman & Scott Bullock, 1995).

L1 is a civilian-used signal, to be broadcasted on the same L1 frequency that currently contains the C/A signal used by all current GPS users. Figure 2 shows the demodulating and decoding signals in GPS system. Implementation will provide C/A code to ensure backward compatibility assured of 1.5 dB increases in minimum C/A code power to mitigate any noise floor increase. Non-data signal component contains a pilot carrier to improve tracking enables greater civil interoperability with Galileo L1 (S.U. Qaisar A.G. Dempster, 2011).

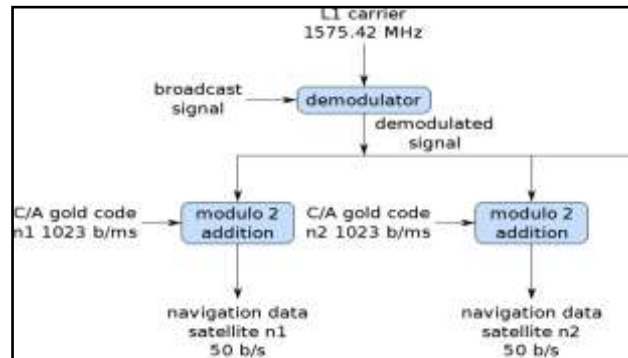

Fig. 2: GPS satellite transmission.

Power Amplifier:

The main purpose of designing power amplifier is to boost the transmitted signal power high enough so that the information data still could be preserved over attenuation of propagation in the distance of microwave transmission. High output power, gain, linearity and efficiency are essential in wireless communication (M. Iwamoto, et al., 2001; Carlos Fuentes, 2008).

Basically, a power amplifier is composed of an active device, usually a single bipolar junction transistor (BJT) or a field effect transistor (FET), DC feed, output-matching network, and input-matching network. The active device acts as a current source driven by the appropriate DC bias and the input signal. The input and output matching networks optimizes the source and the load to the transistor impedances to provide maximum gain.

Parameter of the power amplifier is basically about the power level that the PA can achieve depending on the RF linearity and efficiency requirement. Power amplifier can be categorized based on its classes whether they are the purpose for linear operation (Class A, B, C, and AB) or constant – envelope operation (Class D, E and F) (Chris Bowich, 1997; Alireza Shirvani, 2007).

The overall efficiency of the transistor is defined as the ratio of RF power received by the load to the DC power fed into the amplifier. On top of the efficiency measurement of the power amplifier, another important parameter for high efficient power amplifier is power added efficiency (PAE). Power added efficiency is a measurement of maximum output RF power to input RF power over the DC power fed into the amplifier. Thus, it is important to be able to transfer the maximum amount of DC power to the load as RF power.

A single stage microwave transistor amplifier can be modeled by the circuit in Figure 3, where a matching network is used both sides of the transistor to transform the input and output impedance Z_0 to the source and load impedance Z_S and Z_L . The most useful gain definition for amplifier design is the transducer power gain, which account both source and load mismatch. Transducer power gain can be defined separate effective gain factors for the input (source) matching network, the transistor itself and the output (load) matching network as follow:

$$G_S = \frac{1-|r_S|^2}{|1-S_{22}r_S|^2} \quad (1)$$

$$G_0 = |S_{21}|^2 \quad (2)$$

$$G_L = \frac{1-|r_L|^2}{|1-S_{22}r_L|^2} \quad (3)$$

Then overall transducer gain is $G_T = G_S G_0 G_L$. The effective gains from G_S and G_L are due to the impedance matching of the transistor to the impedance Z_0 .

Parameters Design:

The table 1 below shows the specification and parameter that been use. The design process will start with the calculation base on those parameters.

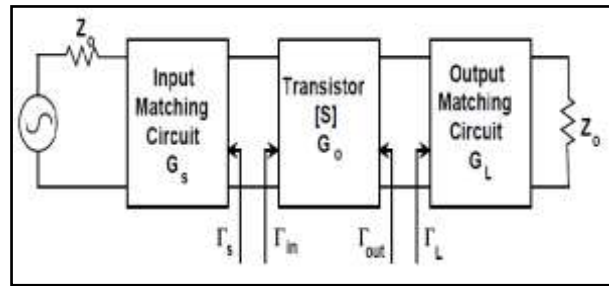

Fig. 3: The General Transistor Amplifier Circuit.

Table 1: Power Amplifier Parameter.

Parameter	Requirement
Operating frequency, f	1.575 GHz
Gain	>10 dB
Transistor	AT-41533

The stability of a small-signal RF amplifier is ensured by deriving set of S-parameters from using measured data or a linear model, and then establishing the value of k -factor stability parameter. If the k -factor is greater than unity, at the frequency and bias level, the expressions for matching impedances at input and output can be evaluated to give a perfect conjugate match for the device (Frederick H. Raab, et al., 2002).

The transistor was defined as unconditionally stable if *Rollet's* condition and the auxiliary condition is are simultaneously satisfied.

$$K = \frac{1 + |\Delta|^2 - |S_{11}|^2 - |S_{22}|^2}{2|S_{12}S_{21}|}, K > 1 \quad (4)$$

$$|\Delta| = |S_{11}S_{22} - S_{12}S_{21}| > 1 \quad (5)$$

The gain can be determined using;

Power gain;

$$G = \frac{|S_{21}|^2 (1 - |\Gamma_L|^2)}{(1 - |\Gamma_{in}|^2) |1 - S_{22}\Gamma_L|^2} \quad (6)$$

Available gain;

$$G_A = \frac{|S_{21}|^2 (1 - |\Gamma_s|^2)}{(1 - |\Gamma_{out}|^2) |1 - S_{11}\Gamma_s|^2} \quad (7)$$

Transducer gain;

$$G_T = \frac{|S_{21}|^2 (1 - |\Gamma_s|^2) (1 - |\Gamma_L|^2)}{|1 - S_{22}\Gamma_L|^2 |1 - \Gamma_{in}\Gamma_s|^2} \quad (8)$$

Noise Figure;

$$F = F_{\min} + \frac{4R_n |\Gamma_s - \Gamma_{opt}|}{Z_o |1 + \Gamma_{opt}|^2 (1 - |\Gamma_s|^2)} \quad (9)$$

Result:

For this project, the transistor model AT- 41533 produced by Hewlett-Packard has been chosen. The bias point of the transistor is $V=2.7V$ and $I=10mA$.

Table 2: S-Parameter at 1575MHz for AT-41533.

Freq(MHz)	S_{11}	S_{12}	S_{21}	S_{22}
1575	0.15984 $\angle 139.5$	0.15175 $\angle 66.239$	2.7728 $\angle 60.784$	0.46999 $\angle -35.75$

Form simulation, k-factor is 1.2375 and *Rollett's* criteria are 0.93413. Therefore, transistor is unconditionally stable at frequency 1.575 GHz.

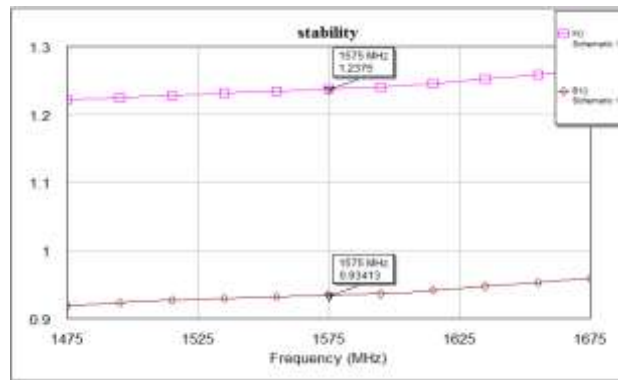

Fig. 4: Graft of Stability.

From the graph, the value of k- factor is 1.2375 which is more than 1 and *Rollett's* criteria are 0.93413 below than 1. So this transistor is unconditionally stable at frequency 1.575 GHz.

Matching network:

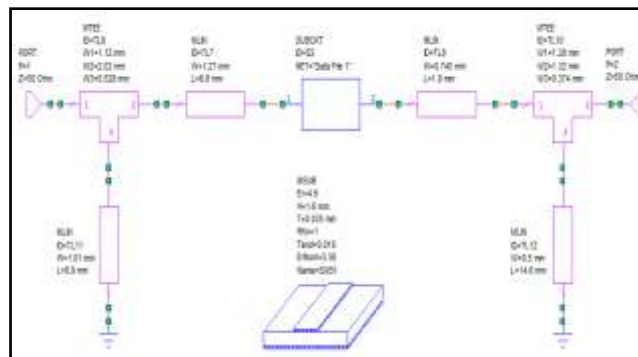

Fig. 5: Single Stub Matching Network.

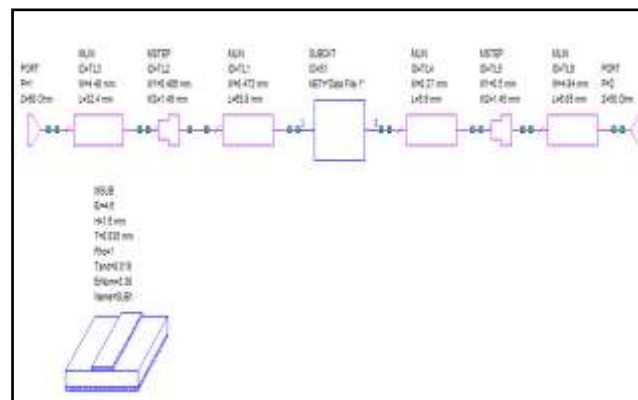

Fig. 6: Quarter-wave Matching Network.

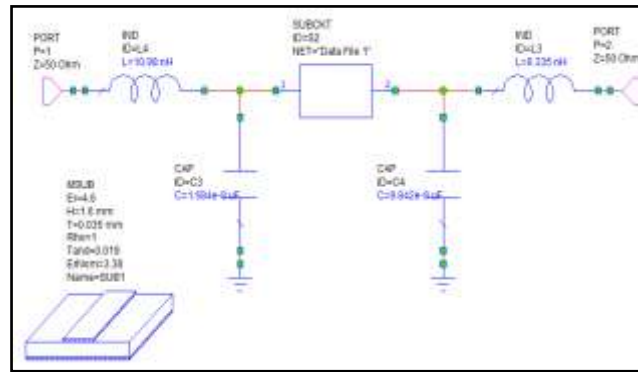

Fig. 7: Lumped Element Matching Network.

Table 3: Comparison of Power Amplifier parameters.

Parameter	Calculation	Simulation
Stability	1.2375	1.2375
Power Gain	15.67	15.6691
Available Gain	14.45	14.4489
Transducer Power Gain	13.65	13.6498

All parameters values from simulation were identical to calculation values.

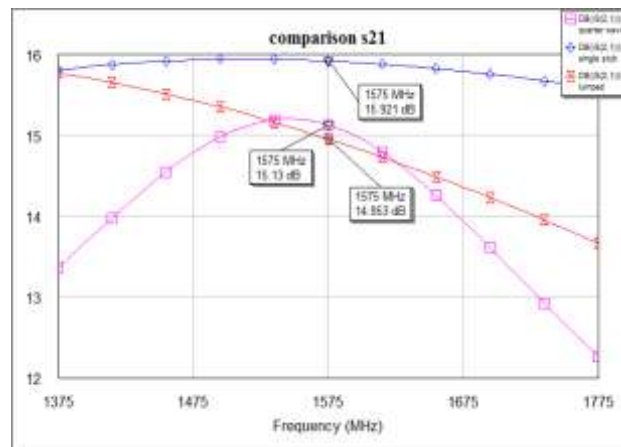

Fig. 8: Comparison of Gain.

Figure 7 shows the value of S21 after the optimization technique was applied to the circuit. Comparison between types of matching shows that the gains for single stub element were increase higher than others matching types.

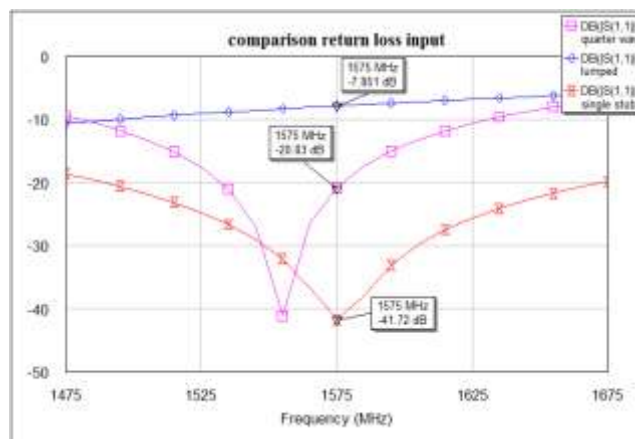

Fig. 8: Comparison Return Loss Input (S11).

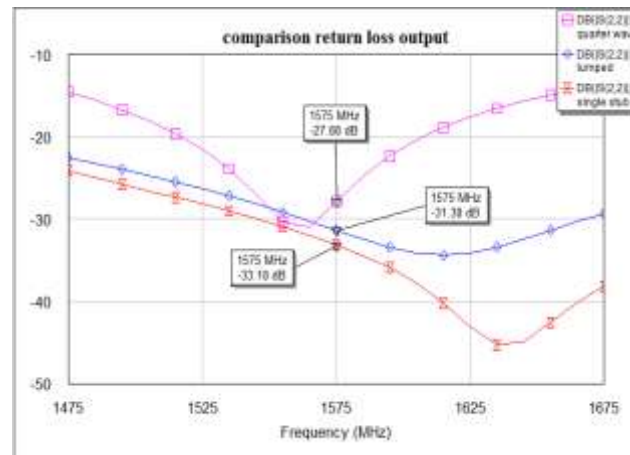

Fig. 9: Comparison Return Loss Output (S22).

From the figure 8 and 9 show the comparison based on type of matching, we can see that input return loss for lumped element matching is not very good and not stable compared than other types of matching. It's because above than -10dB which is the good value for return losses. For output return loss all type of matching were stable which is more than -10 dB. However, output return loss for lumped element is not good and stable compared than another type. For stub matching input and output return loss is very good than others type which is input return loss at -41.72 dB and output return loss at -33.18 dB.

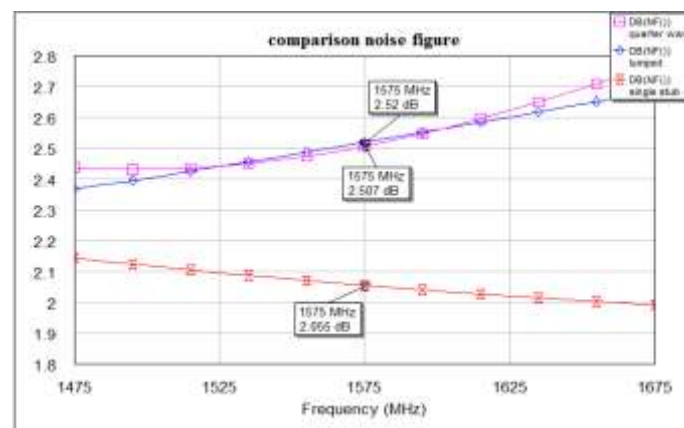

Fig. 10: Comparison of Noise Figure.

Table 4: Comparison result based on type of Matching.

Parameter	Lumped element	Quarter wave	Single stub
Gain (S_{21})	14.953 dB	15.13 dB	15.921 dB
NF	2.52 dB	2.507 dB	2.055 dB
S_{11}	-7.851 dB	-20.83 dB	-41.72 dB
S_{22}	-31.38 dB	-27.88 dB	-33.18 dB

Discussion:

An amplifier with absolute stability or unconditionally stability ($K > 1$) means that the two-port is stable for all passive terminations at either the load or the source. Lumped element matching network can't fulfill the requirement of the GPS application because the operating frequency for GPS is high. The actual lumped-elements capacitor and inductor only used for lower frequency.

Quarter wave is a simplest impedance matching but rarely used in practical because it cannot match all load impedances and larger size. Single stub is a practical matching because it easy to adjustable the length of line between the load and stub. The single-stub matching technique give the best performance with gain, noise figure, input return loss and output return loss is 15.921dB , 2.055dB , -41.72dB and -33.18dB respectively.

Conclusion:

GPS satellites transmit two low power radio signals, designated L1 and L2. Civilian GPS uses the L1 frequency of 1575.42 MHz in the UHF band. The transistor AT-41533 produced by Avago was choosing. The

gain and efficiency of the amplifier is limited by the characteristics of the transistor. To verify that the model provided an accurate representation of our device samples, small signal scattering parameters generated from AWR software were compared to the ones given in the datasheet.

S-parameters of a general purpose NPN transistor with bias condition of $V_{DS}=2.7V$ and $I_{DQ}=10mA$, at 1.575 GHz. Most important parameters that define an RF Power Amplifier are output power, gain, linearity, stability, DC supply voltage, efficiency and ruggedness. Choosing the bias points of an RF Power Amplifier can determine the level of performance ultimately possible with that PA.

The Power Class of the amplification determines the type of bias applied to an RF power transistor. The Power Amplifier's Efficiency is a measure of its ability to convert the DC power of the supply into the signal power delivered to the load.

Single stub matching network is the good impedance matching because it can fulfill the requirement parameter of the GPS application. It's suitable for high frequency and easy to adjustable the length and width. For quarter wave matching, not all load impedance can match by using this type and rarely use in practical. Lumped element matching not suitable use for GPS frequency because it's suitable for lower frequency up to approximately 1 GHz

The transistor AT-41533 produced by Avago was chosen. S-parameters of a general purpose NPN transistor with bias condition of $V_{DS}=2.7V$ and $I_{DQ}=10mA$, at 1.575 GHz. Most important parameters that define an RF Power Amplifier are output power, gain, linearity, stability, DC supply voltage, efficiency and ruggedness.

The Power Amplifier's Efficiency is a measure of its ability to convert the DC power of the supply into the signal power delivered to the load. Single stub matching techniques give the best performance compare to the other techniques.

ACKNOWLEDGEMENT

Thanks to Universiti Teknikal Malaysia Melaka for funding this research under shot term grant.

REFERENCES

- Alireza Shirvani, 2007. "RF Power Amplifiers", SVC SSCS RFIC Course, Marvell.
- Carlos Fuentes, 2008. "Microwave Power Amplifier Fundamentals", Giga-tronics Incorporated.
- Chris Bowich, 1997. "RF Circuit Design", 2nd edition, Indianapolis: Newnes, pp: 150-158.
- Frederick H. Raab, Peter Asbeck, Steve Cripps, Peter B. Kenington, Zoya B. Popovich, Nick Potheary, John F. Sevic and Nathan O. Sokal, 2002. "RF and Microwave Power Amplifier and Transmitter Technologies", Part 2.
- Iwamoto, M., A. Williams, P.F. Chen, A.G. Metzger, L.E. Larson, P.M. Asbeck, 2001. "An Extended Doherty Amplifier With High Efficiency Over a Wide Power Range", IEEE Trans. Micro. Theory Tech., 49(12): 2472-2478.
- Larry Huffman, Scott Bullock, 1995. "Digital Modulation And Demodulation Within E-System Differential And Receiver".
- Qaisar, S.U., A.G. Dempster, 2011. "Cross-correlation performance assessment of global positioning system (GPS) L1 and L2 civil codes for signal acquisition", IET. Radar Sonar Navigation, 5(3): 195-203.